

## 13" Bench Drill Press



## Operator's Manual

Record the serial number and date of purchase in your manual for future reference.

Serial Number: \_\_\_\_\_ Date of purchase: \_\_\_\_\_

For technical support or parts questions, email [techsupport@rikontools.com](mailto:techsupport@rikontools.com) or call toll free at (877)884-5167

# Operator Safety: Required Reading

**IMPORTANT!** Safety is the single most important consideration in the operation of this equipment. **The following instructions must be followed at all times.**

There are certain applications for which this tool was designed. We strongly recommend that this tool not be modified and/or used for any other application other than that for which it was designed. If you have any questions about its application, do not use the tool until you have contacted us and we have advised you.

## General Safety Warnings

**KNOW YOUR POWER TOOL.** Read the owner's manual carefully. Learn the tool's applications, work capabilities, and its specific potential hazards.

### **⚠ DANGER**

#### **ALWAYS GROUND ALL TOOLS.**



If your tool is equipped with a three-pronged plug, you must plug it into a three-hole electric receptacle. If you use an adapter to accommodate a two-pronged receptacle, you must attach the adapter plug to a known ground. Never remove the third prong of the plug.

#### **ALWAYS AVOID DANGEROUS ENVIRONMENTS.**

Never use power tools in damp or wet locations. Keep your work area well lighted and clear of clutter.

### **⚠ DANGER**

#### **ALWAYS REMOVE THE ADJUSTING KEYS AND WRENCHES FROM TOOLS AFTER USE.**



Form the habit of checking to see that keys and adjusting wrenches are removed from the tool before turning it on.

**ALWAYS KEEP YOUR WORK AREA CLEAN.** Cluttered areas and benches invite accidents.

### **⚠ DANGER**

#### **ALWAYS KEEP VISITORS AWAY FROM RUNNING MACHINES.**



All visitors should be kept a safe distance from the work area.

#### **ALWAYS MAKE THE WORKSHOP CHILDPROOF.**

Childproof with padlocks, master switches, or by removing starter keys.

### **⚠ DANGER**



**NEVER OPERATE A TOOL WHILE UNDER THE INFLUENCE OF DRUGS, MEDICATION, OR ALCOHOL.**

### **⚠ DANGER**



#### **ALWAYS WEAR PROPER APPAREL.**

Never wear loose clothing or jewelry that might get caught in moving parts. Rubber-soled footwear is recommended for the best footing.

### **⚠ DANGER**



#### **ALWAYS USE SAFETY GLASSES AND WEAR HEARING PROTECTION.**

Also use a face or dust mask if the cutting operation is dusty.

### **⚠ DANGER**



#### **NEVER OVERREACH.**

Keep your proper footing and balance at all times.

### **⚠ DANGER**



#### **NEVER STAND ON TOOLS.**

Serious injury could occur if the tool is tipped or if the cutting tool is accidentally contacted.

**⚠ DANGER****ALWAYS DISCONNECT TOOLS.**

Disconnect tools before servicing and when changing accessories such as blades, bits, and cutters.

**ALWAYS AVOID ACCIDENTAL STARTING.**

Make sure switch is in "OFF" position before plugging in cord.

**NEVER LEAVE TOOLS RUNNING UNATTENDED.****⚠ DANGER****ALWAYS CHECK FOR DAMAGED PARTS.**

Before initial or continual use of the tool, a guard or other part that is damaged should be checked to assure that it will operate properly and perform its intended function. Check for alignment of moving parts, binding of moving parts, breakage of parts, mounting, and any other conditions that may affect its operation. A guard or other damaged parts should immediately be properly repaired or replaced.



## Special Safety Rules For Drill Press

1. Do Not operate the Drill Press until it is assembled and you have read the instructions.
2. Do not operate the Drill Press unless you are familiar with its safe operation. If you are not familiar with the operation of a Drill Press seek advice from your supervisor, instructor or other qualified individual.
3. If you are using a bench top Drill Press, it must be securely fastened to a stand or bench.
4. If you are operating a floor Drill Press it must be securely fastened to the floor.
5. Always clear the table and work area before turning on the Drill Press.
6. Always use drill bits, cutting tools and accessories with a 1/2" shank or less.
7. Never place hands near the drill bit, cutting tool or accessory.
8. Never wear loose clothing, gloves or ties while operating the Drill Press.
9. Always have a firm footing while operating the Drill Press.
10. Always keep work surface and work areas clear of debris.
11. Never attempt to do set-up work, assembly or layout work on the Drill Press while it is in operation.
12. Never start the Drill Press with the drill bit, cutting tool or accessory in contact with the work-piece.
13. Always lock all table, column and head locks before turning on the Drill Press.
14. Never operate the Drill Press with a damaged drill bit, cutting tool or accessory.
15. Always check the drill bit, cutting tool or accessory in tight in the chuck.
16. Never operate the Drill Press with the chuck key in the chuck.
17. Always adjust the depth stop to avoid drilling into the table surface.
18. Never drill material unless it is properly supported. Non flat work-pieces require additional support.
19. Always clamp the work piece to the table.
20. Always support large work-pieces at the same height as the table.
21. Never remove the work-piece or clear the table until the Drill Press comes to a complete stop.
22. Always wear a face shield and safety glasses while operating the Drill Press.
23. Never operate the Drill Press with missing, damaged, worn, loose or defective parts.
24. Never adjust, change speeds or perform maintenance on the Drill Press while it is operating.
25. Always clean the work surface and work area when finished operating the Drill Press.
26. Always disconnect the power when adjusting or performing maintenance on the Drill Press.
27. Always disconnect the power when finished using the Drill Press to prevent accidental operation.

**Note:** This owner's manual is not a teaching aid. Use of this owner's manual is intended to show assembly, adjustments, and general use.

**SAVE THESE INSTRUCTIONS.**

**Refer to them often.**

## Table of Contents

Safety Warnings.....	2-3
Drill Press Safety Rules .....	3
Specifications .....	4
Contents of Package.....	5
Unpacking and Cleaning the Drill Press.....	5
Getting To Know Your Drill Press.....	6
Assembly .....	7
Base and Column Assembly.....	7
Head Assembly.....	7-8
Installing/Removing the Chuck and Arbor.....	9-10
Installing the Table.....	10
Adjustment and Operation.....	11
Head Adjustments .....	11
Table Adjustments.....	11
Changing Spindle Speeds.....	11-12
Setting the Spindle Lock.....	12
Setting the Drill Depth.....	12
Maintenance.....	13
Wiring Diagram.....	14
Electrical Requirements.....	14
Troubleshooting .....	15
Parts Explosion .....	16
Parts List .....	17
Notes .....	18
Warranty .....	19

## Specifications

<b>Model No.</b>	<b>30-120</b>
<b>Specifications</b>	
Type	Bench
Horsepower	1/2 HP
Amps	7.5
Volts	115V, 60 Hz
RPM	1,720
Speed Range (RPM)	220 - 3,600
Speeds	16
Chuck Size	5/8"
Chuck Taper	JT3
Drilling Capacity	5/8"
Spindle Travel	3-1/8"
Spindle Taper	MT2
Quill Diameter	2-3/16"
<b>Overall</b>	
Table	11-3/16" (Round)
Table Tilts	45°
Table Rotates	360°
Maximum Chuck to Table	16-1/4"
Maximum Chuck to Base	24-5/8"
Column Diameter	2-7/8"
Height	42"
Base Size	17-3/4" x 10-1/2"
Net Weight	102 lbs.
Shipping Weight	112 lbs.
Shipping Carton	35" x 19-1/2" x 11"
<b>Warranty</b>	<b>5 Years</b>

# Contents of Package

Model 30-120 13" Bench Drill Press is shipped complete in one box.

## 1. Unpacking and Checking Contents

- Separate all "loose parts" from packaging materials and check each item with "Table of Loose Parts" to make sure all items are accounted for, before discarding any packaging material.
- With the help of another person, carefully lift the Drill Press head out of the box.
- Remove protective oil that is applied to the table and column before assembly. Use any ordinary house hold type grease or spot remover.
- Apply a coat of paste wax to the table and column to prevent rust. Wipe all parts thoroughly with a clean dry cloth.

## TABLE OF LOOSE PARTS

Item	Part Name	Qty
A	Drill Press Head	1
B	Arm	1
C	Table Support	1
D	Table	1
E	Column Assembly	1
F	Base	1
G	Loose Bag	2
H	Chuck	1
I	Owner's manual	1
J	Cast iron handle	1

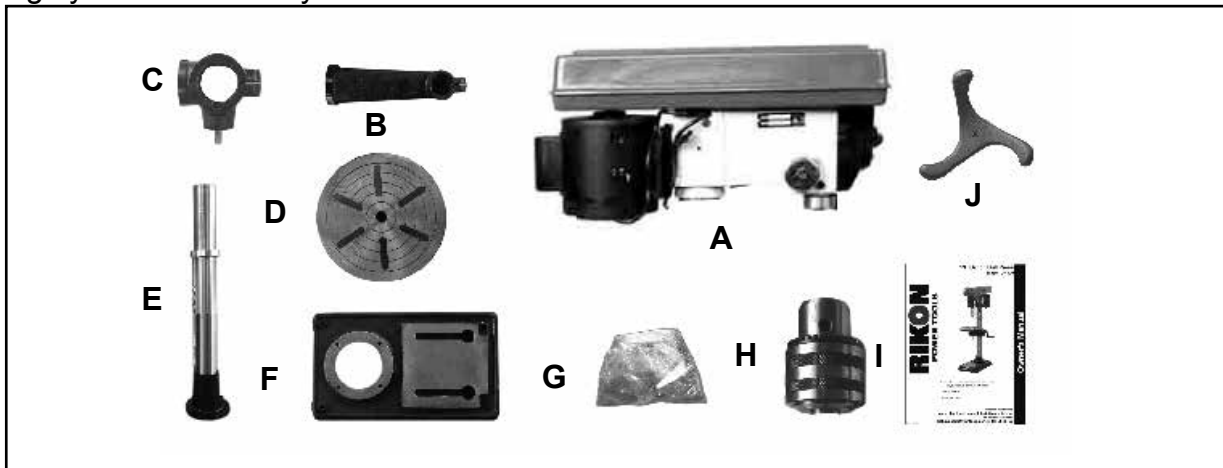

## Tools required for assembly



1. Allen wrenches (provided).



2. Rubber mallet or block of wood and hammer.



3. Adjustable wrench or open end wrench.



4. Household grease remover.



5. Hex. Wrench (provided)

# Getting to Know Your Drill Press

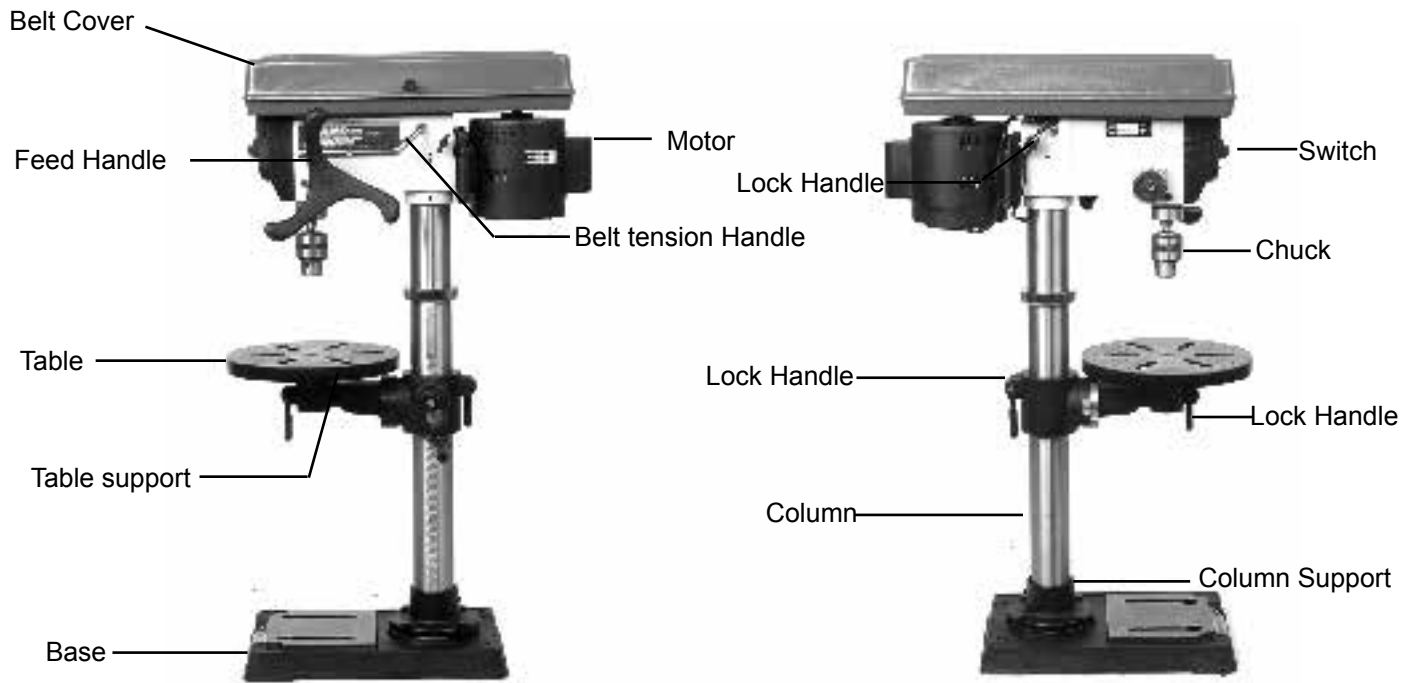

# Assembly

## Base and Column Assembly

1. Place the base (A-Fig. 1) on a level floor where the machine will be used.
2. Attach the column (B-Fig.1) to the base (A-Fig. 1) using four M8x20 hex bolts. Tighten all four bolts.
3. Using an allen wrench (C-Fig. 2) remove the column collar (D-Fig. 2) as shown.
4. Insert the worm elevation gear (E-Fig. 3) into the table support bracket (F-Fig. 3) as shown.
5. Place rack (G-Fig. 4) inside the table support bracket (F-Fig. 4) lining up the teeth as shown.
6. Slide the table support and rack assembly over the column and replace the column collar.

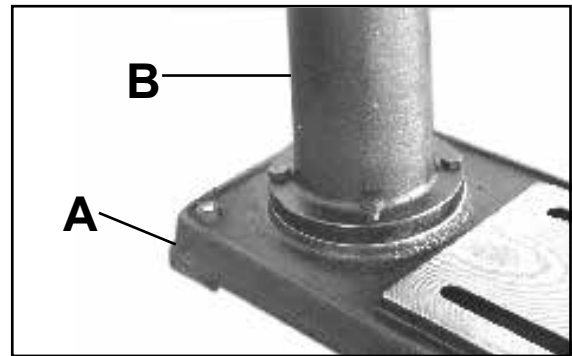

Figure 1

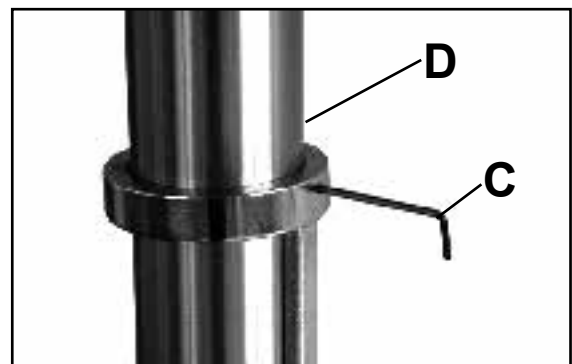

Figure 2

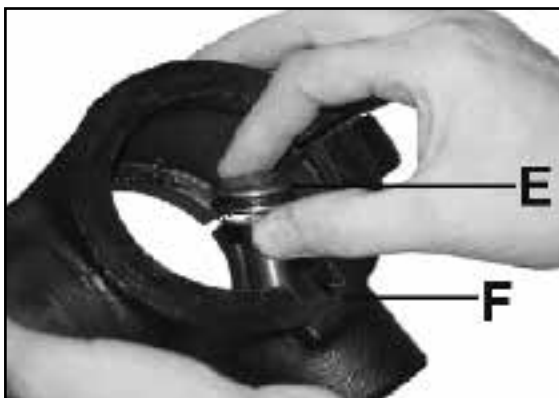

Figure 3

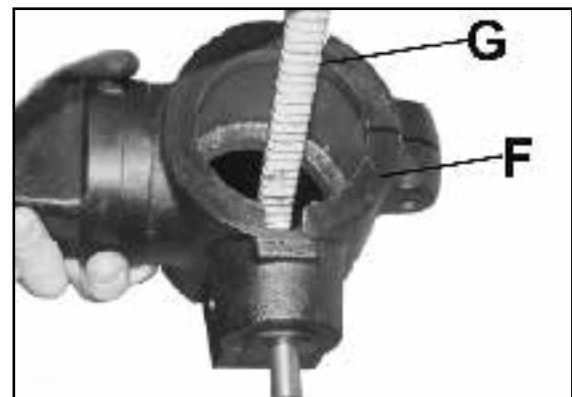

Figure 4

## Head Assembly

### **NOTE:**

Assistance is needed for this next step.

1. Place the drill press head (A-Fig. 5) onto the column (B-Fig. 5) as far as it will go.

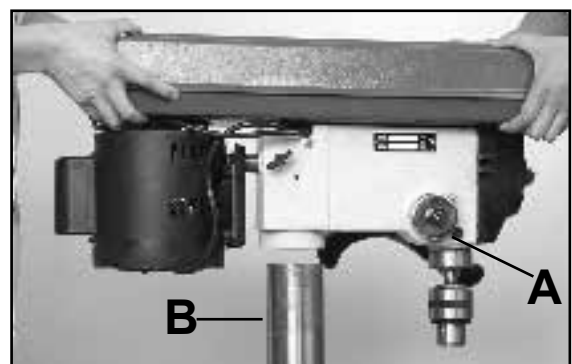

Figure 5

## Head Assembly

2. Align the drill press head (A-Fig. 6) with the base of the drill press (B-Fig. 6).

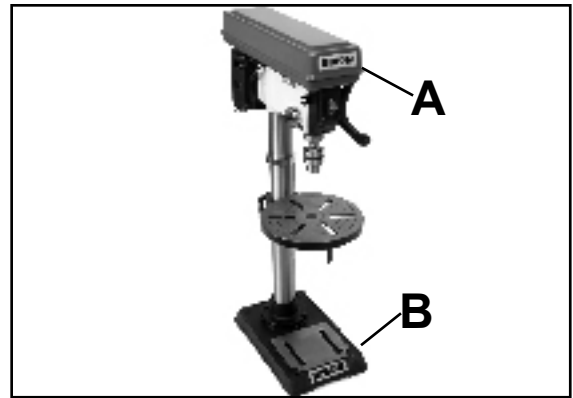

Figure 6

3. Tighten the drill press head (A-Fig. 7) to the column (B-Fig. 7) by tightening the two set screws on the right side of the head as shown.



Figure 7

4. Attach the feed handwheel to the hub. Fig. 8



Figure 8

5. Install the idler pulley and drive belts. Simply slide the pivot post of the idler pulley into the corresponding hole in the drill press head as shown. The small drive belt (M24) is mounted to the spindle pulley and the large drive belt (M25) is mounted to the motor pulley. Fig. 9



Figure 9



## INSTALLING/REMOVING CHUCK AND ARBOR

**IMPORTANT!** It is important that the chuck and arbor are free of any grease or rust protection. Use ordinary household grease remover.

### INSTALLING THE CHUCK AND ARBOR

1. Open the chuck jaws as wide as possible to prevent any damage. (Fig. 10)
2. Insert the arbor (A-Fig. 11) into the chuck (B-Fig. 11) as shown.
3. Carefully insert the chuck and arbor assembly into the spindle, making sure to align the flat part of the arbor with the spindle. (Fig. 12)
4. Using a mallet or wood and hammer, drive the chuck and arbor assembly into the spindle. This will properly seat the chuck assembly on the spindle. (Fig. 13)
5. Close the chuck jaws with the chuck key provided.

**NOTE:** NEVER HIT THE CHUCK ASSEMBLY WITH A METAL HAMMER. This could damage the chuck assembly or spindle.

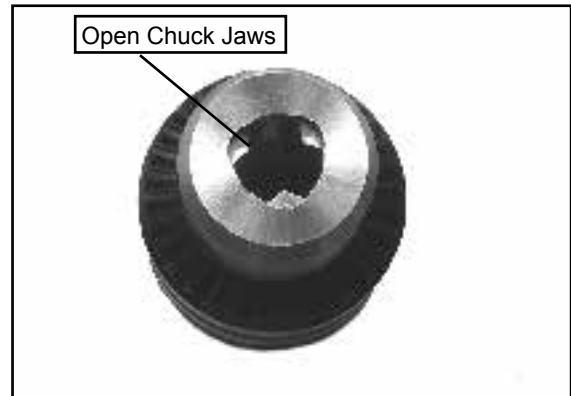

Figure 10



Figure 11



Figure 12

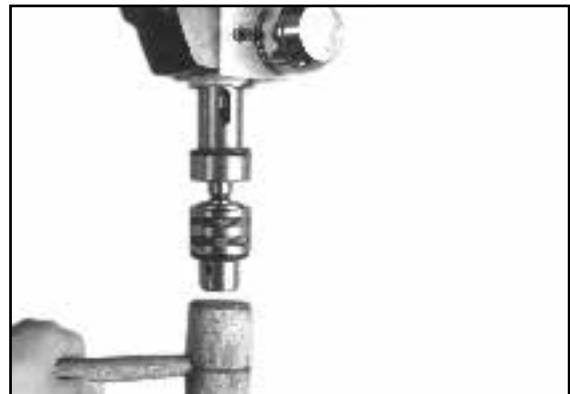

Figure 13

## REMOVING THE CHUCK

1. Open the chuck jaws as wide as possible to prevent damage.
2. Lower the spindle until the slot in the spindle is exposed. (Fig. 14)
3. Position the table approximately 1/2" below the extended chuck.
4. Turn the chuck until a through hole is exposed in the spindle.
5. Insert the Key-drift provided into the slot. (Fig. 15)
6. Gently tap the key-drift with a mallet to release the chuck.



Figure 14



Figure 15

## INSTALLING THE TABLE

1. Install the arm onto the table support with hex bolt (A-Fig. 16) and make sure the scale is on zero position (B-Fig. 16). If necessary, adjust the hex socket screw (C-Fig. 16) to level the table 90 degree to the spindle.

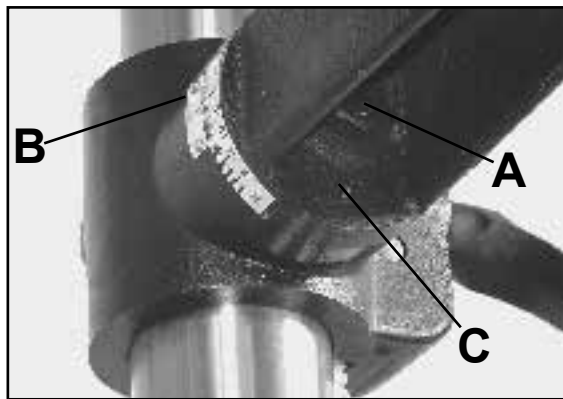

Figure 16

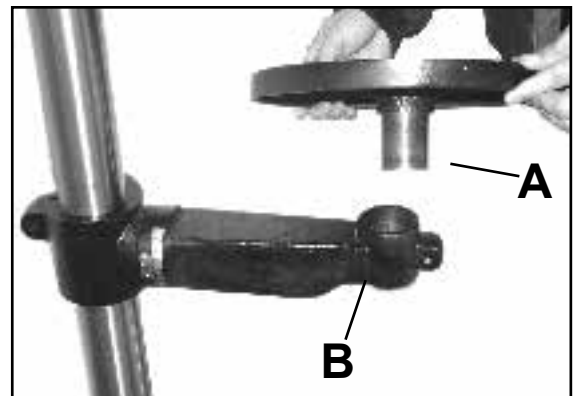

Figure 17

2. Insert the table post (A-Fig. 17) into the table support bracket (B-Fig.17) as shown.
3. Tighten the locking lever (A-Fig. 18) onto the table support bracket (B-Fig. 18) and install the table raising/lowering handle (C-Fig. 18).

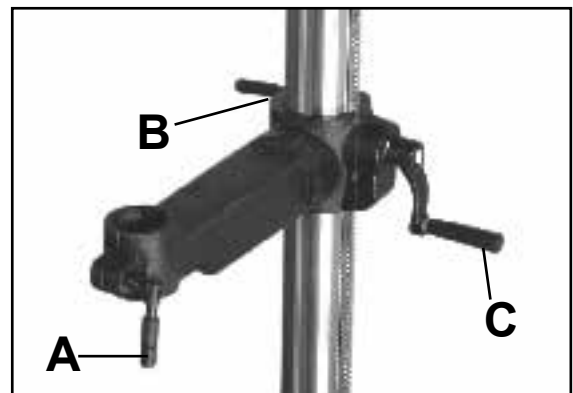

Figure 18

## TABLE ADJUSTMENTS

### Raising and Lowering the Table

1. Loosen the column lock (A-Fig. 19) on the table support bracket (B-Fig. 19).
2. Turn the crank to raise or lower the table to the desired height.
3. Tighten the column lock (A-Fig. 19).

The table can rotate 360° by loosening the table lock handle and turning to the desired position. (Fig. 20)

### TILTING THE TABLE

1. Loosen the nut below the table. (Fig. 21)
2. Tilt table to desired angle.
3. A tilt scale and pointer are provided on the bracket to indicate the angle.
4. Tighten nut.

### CHANGING SPINDLE SPEEDS

#### **WARNING!**

Disconnect machine from the power source.

1. Turn off and disconnect the power to the Drill Press.
2. Open belt cover.
3. Release the tension on the belt by loosening the belt tension lock (A-Fig. 22) and pull the tension handle backward on the motor (B-Fig. 22).
4. Choose the desired speed by referring to the speed selection chart.

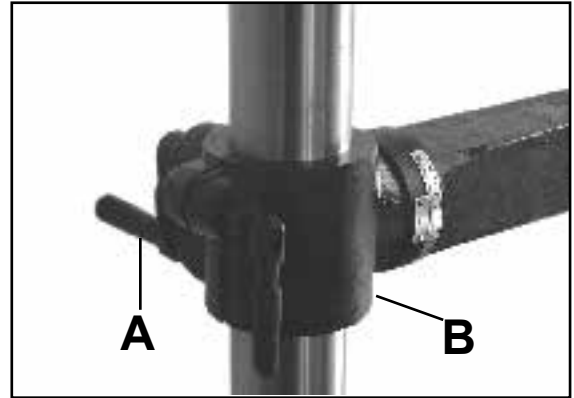

Figure 19

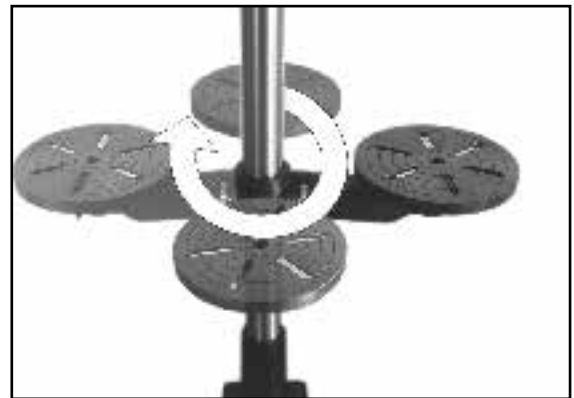

Figure 20



Figure 21



Figure 22

## CHANGING SPINDLE SPEEDS CONT.

- Place the belt on the pulleys in relation to the speed chosen on the speed selection chart starting with the motor pulley first. (Fig. 23)
- Push the belt tension handle backward on the motor until there is approximately 1/2" deflection in the belt. (Fig. 24)
- Tighten the belt tension lock handle.
- Close the belt guard.
- Reconnect the Drill Press to the power.

220	300	430	480
590	650	720	850
900	950	1600	1900
2000	2500	2900	3600

Figure 23

## SETTING THE SPINDLE LOCK

- Loosen the depth stop collar lock (A-Fig. 25) as shown.
- Lower the spindle to the desired depth. (Fig. 26)
- Turn the depth stop collar clockwise until the collar stops (B-Fig. 25).
- Tighten the depth stop collar lock.



Figure 24

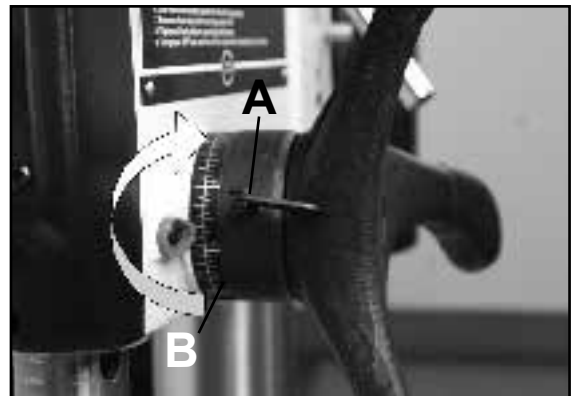

Figure 25

### NOTE:

Figure 26 shows the spindle in the locked position.

## SETTING THE DRILL DEPTH

- With the spindle in the up position, loosen the depth stop collar lock (A-Fig. 25) as shown.
- Turn the depth stop collar clockwise until the pointer reads the desired drill depth on the scale (B-Fig. 25).
- Tighten the depth stop collar lock.



Figure 26

## Maintenance

**WARNING:** To avoid injury due to unexpected starting, before cleaning or carrying out maintenance work, switch off and disconnect the drill press from the power source.

1. Never use water or other liquids to clean the drill press. Use a dry brush.
2. Regular maintenance of the drill press will prevent unnecessary problems.
3. Keep the table clean to ensure accurate cutting.
4. Keep the outside of the machine clean to ensure accurate operation of all moving parts and prevent excessive wear.
5. Frequently blow out any dust that may accumulate on the motor.
6. Apply paste wax to the table and column, to help keep the surface clean.
7. Check belts for wear and replace.

## LUBRICATION

All of the ball bearings are packed with grease at the factory. They require no further lubrication.

Periodically lubricate the worm gear (part# 18C) in the table elevation mechanism, the rack bar (part# 2C), and the spline (grooves) in the spindle (part#15A). This will keep the operation of the drill press smooth.

## WIRING DIAGRAM

**WARNING:** This machine must be grounded. To avoid electrocution or fire, any repairs to electrical system should be done only by a qualified electrician, using genuine replacement parts.

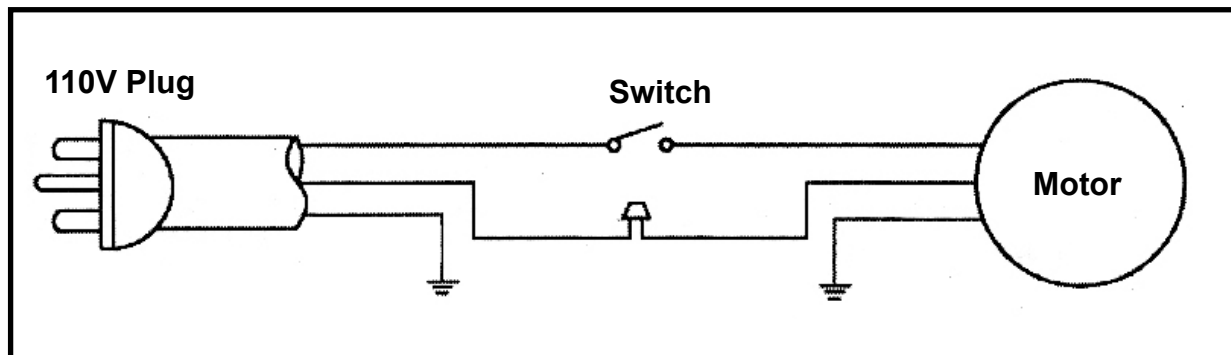

# Electrical Requirements

In the event of a malfunction or breakdown, grounding provides a path of least resistance for electric current to reduce the risk of electric shock. This tool is equipped with an electric cord having an equipment-grounding conductor and a grounding plug. The plug must be plugged into a matching outlet that is properly installed and grounded in accordance with all local codes and ordinances.

Do not modify the plug provided. If it will not fit the outlet, have the proper outlet installed by a qualified electrician.

Improper connection of the equipment-grounding conductor can result in a risk of electric shock. The conductor, with insulation having an outer surface that is green with or without yellow stripes, is the equipment-grounding conductor. If repair or replacement of the electric cord or plug is necessary, do not connect the equipment-grounding conductor to a live terminal.

Check with a qualified electrician or service personnel if the grounding instructions are not completely understood, or if in doubt as to whether the tool is properly grounded.

Use only three wire extension cords that have three-prong grounding plugs and three-pole receptacles that accept the tool's plug.\*

Repair or replace a damaged or worn cord immediately.

This tool is intended for use on a circuit that has an outlet that looks the one illustrated in Figure A below. The tool has a grounding plug that looks like the grounding plug as illustrated in Figure A below. A temporary adapter, which looks like the adapter as illustrated in Figure B below, may be used to connect this plug to a two-pole receptacle, as shown in Figure B if a properly grounded outlet is not available.\*\* The temporary adapter should only be used until a properly grounded outlet can be installed by a qualified electrician. The green colored rigid ear or tab, extending from the adapter, must be connected to a permanent ground such as a properly grounded outlet box.

\* Canadian electrical codes require extension cords to be certified SJT type or better.

\*\* Use of an adapter in Canada is not acceptable.

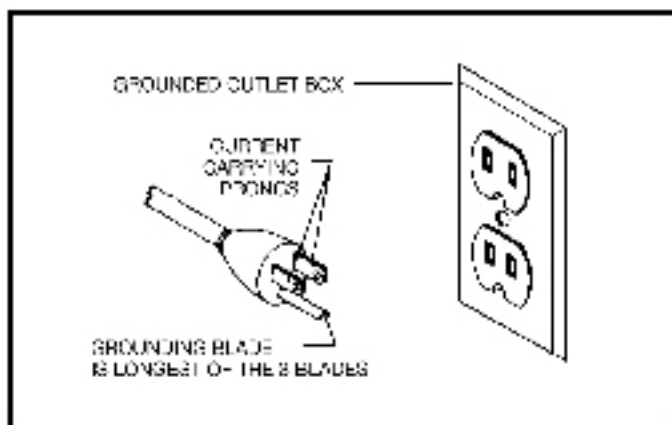

Fig. A

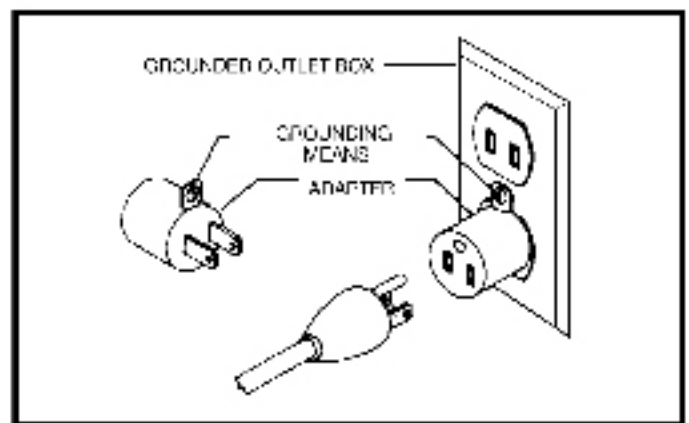
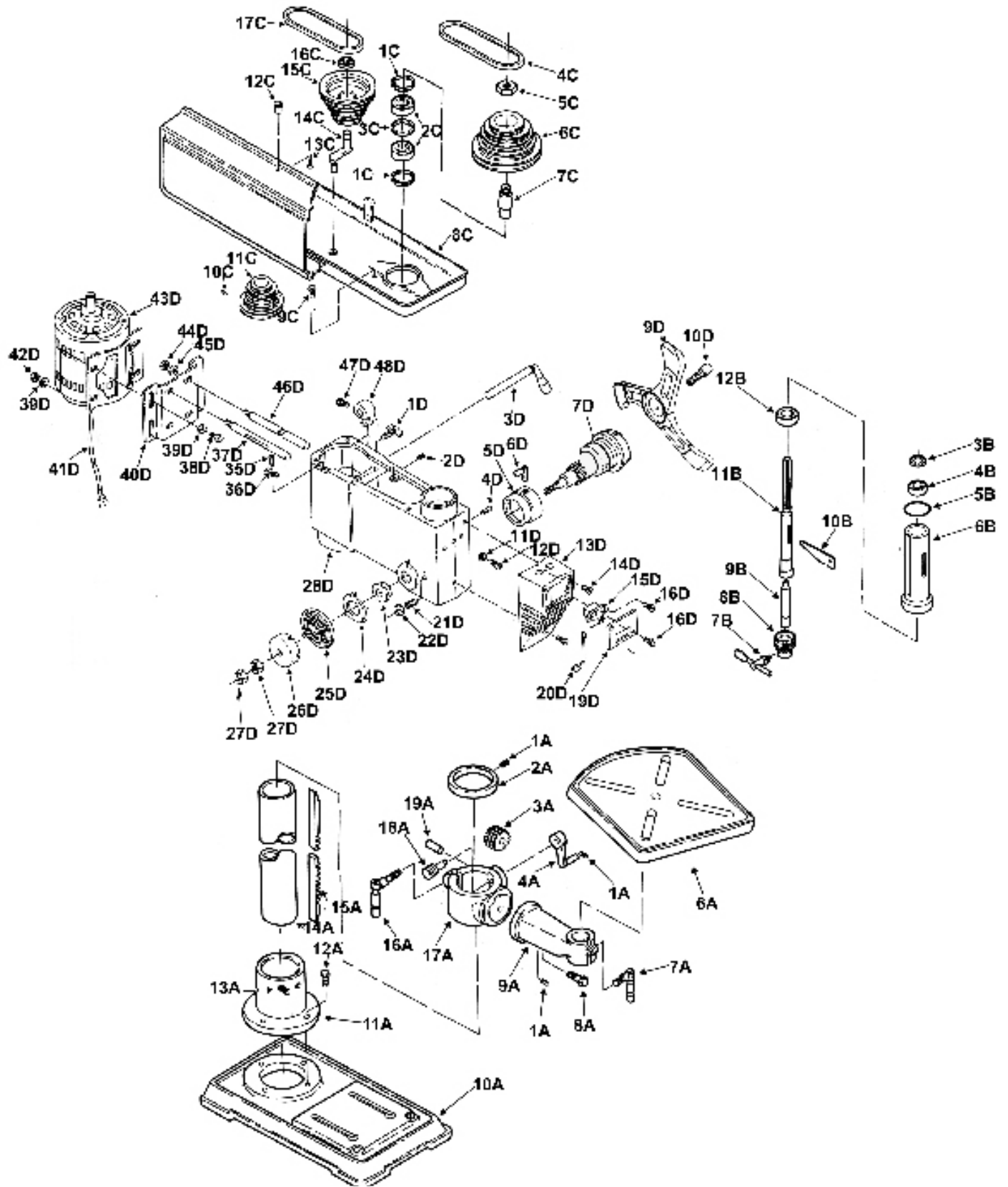

Fig. B

## Trouble Shooting

TROUBLE	PROBABLE CAUSE	REMEDY
Noisy operation	<ol style="list-style-type: none"> <li>1. Incorrect belt tension.</li> <li>2. Dry spindle.</li> <li>3. Loose spindle pulley.</li> <li>4. Loose motor pulley.</li> </ol>	<ol style="list-style-type: none"> <li>1. Adjust tens on.</li> <li>2. Lubricate spindle.</li> <li>3. Checking tightness of retaining nut on pulley and tighten if necessary.</li> <li>4. Tighten setscrews in pulleys.</li> </ol>
Drill bit burns materia	<ol style="list-style-type: none"> <li>1. Incorrect speed.</li> <li>2. Chips not coming out of hole.</li> <li>3. Dull drill bit.</li> <li>4. Feeding too slow.</li> <li>5. Not Lubricated</li> </ol>	<ol style="list-style-type: none"> <li>1. Adjust speed.</li> <li>2. Retract drill bit frequently to clear chips.</li> <li>3. Resharpen drill bit.</li> <li>4. Faster the speed.</li> <li>5. Lubricate drill bit.</li> </ol>
Drill bit eads off, hole not round	<ol style="list-style-type: none"> <li>1. Hard grain in wood or lengths of cutting lips and/ or angles not equal.</li> <li>2. Bent drill bit.</li> </ol>	<ol style="list-style-type: none"> <li>1. Resharpen drill bit correctly</li> <li>2. Replace drill bit.</li> </ol>
Wood splinters on underside of workpiece	<ol style="list-style-type: none"> <li>1. No "back up material" under workpiece.</li> </ol>	<ol style="list-style-type: none"> <li>1. Use "back-up material"</li> </ol>
Wood piece pulled loose from hands	<ol style="list-style-type: none"> <li>1. Not supported or clamped properly.</li> </ol>	<ol style="list-style-type: none"> <li>1. Support workpiece or clamp it.</li> </ol>
Drill bit binds in workpiece	<ol style="list-style-type: none"> <li>1. Workpiece pinching drill bit or excessive feed pressure.</li> <li>2. Improper belt tension, belt slips.</li> </ol>	<ol style="list-style-type: none"> <li>1. Support workpiece or clamp it.</li> <li>2. Adjust belt tension.</li> </ol>
Excessive drill bit runout or wobble	<ol style="list-style-type: none"> <li>1. Bent drill bit.</li> <li>2. Worn spindle bearings.</li> <li>3. Drill bit not properly installed in chuck.</li> <li>4. Chuck not properly installed.</li> </ol>	<ol style="list-style-type: none"> <li>1. Use a straight drill bit.</li> <li>2. Replace bearings.</li> <li>3. Install drill bit properly.</li> <li>4. Install chuck properly.</li> </ol>
Quill Returns too slow or too fast	<ol style="list-style-type: none"> <li>1. Spring has improper tension.</li> </ol>	<ol style="list-style-type: none"> <li>1. Adjust spring tension.</li> </ol>
Chuck will not stay attached to spindle, it falls off when trying to install it	<ol style="list-style-type: none"> <li>1. Dirty, grease, or oil on the tapered inside surface of chuck or on the spindle tapered surface.</li> </ol>	<ol style="list-style-type: none"> <li>1. Using a household detergent clean the tapered surface of the chuck and spindle to remove all dirt, grease and oil.</li> </ol>

# Parts Explosion





# Parts List

Key Part No. No.	Description	Key Part No. No.	Description
1A 1-M6X10GB80B	Screw-Hex Soc Set M6	14C 1-1705007	Pivot-Idler
2A 1-1501011	Collar-Rack	15C 1-1505006-02001G	Pulley-Center
3A 1-1501006	Gear-Helical	16C 1-BRG80202GB278	Bearing-Ball 15mm
4A 1-1501009-10001G	Crank	1D 1-1502005	Knob-Motor Adjusting
6A 1-1301014-02001G	Table	2D 1-M6X8GB80B	Screw-Socket Set M10
7A 1-1501013-01001S	Clamp-Table	3D 1-1502004	Handle-Belt Tension
8A 1-M16X35GB5781B	Screw-Hex Head M16x20-35	4D 1-1304010	Pin-Stop
9A 1-1301005-00001G	Arm-Table w/Scale	5D 1-1304003-00001Y	Ring-Depth Stop w/Scale
10A 1-1301001-01001G	Base	6D 1-1504012	Lock-Depth Screw
11A 1-1501002-02001G	Support Column	7D 1-1304002	Hub
12A 1-M10X40GB5781B	Screw-Hex HD M10x1.5-40	9D 1-1304011-02001Y	Cast iron handwheel
13A 1-M10X12GB80B	Screw-Hex Soc Set M10	10D 1-M8X20GB70B	Socket head screw
14A 1-1501003-02	Tube Column	11D 1-WSH5GB862D2B	Lock Washer Ext.M5
15A 1-1501010-01	Rack	12D 1-M5X8GB818B	Screw-Pan HD M5
16A 1-1501012-01001S	Clamp-Column	13D 1-U1302008-00001S	Box Switch
17A 1-1501004-00001G	Support-Table w/Indicator	14D 1-M5X16GB818B	Screw-Pan HD M5
18A 1-1501008	Worm-Elecaton	15D 1-C13-8B	Switch-Locking
19A 1-1501007	Pin-Gear	16D 1-ST4D2X9D5GB845Z	Screw-Pan HD M4.2
3B 1-CLP11GB894D1B	Ring-Retaining	19D 1-1502009-02	Cover-Switch Plate
4B 1-BRG80201GB278	Bearing-Ball 17mm	20D 2-U1318085C-636	Lead Asm.3
5B 1-1303003	Washer-Rubber	21D 1-1302021	Screw-Set Special 10
6B 1-1303002-02	Tube-Quill	22D 1-M8GB6170B	Nut-Hex M10x1.5
7B 1-Z303116-1	Key-Chuck	23D 1-1504006	Seat-Spring
8B 1-Z103116	Chuck	24D 1-1504007	Retainer-Spring
9B 1-Z402003	Arbor	25D 1-1504009	Spring-Torsion
10B 1-1503008	Key-Drift	26D 1-1504008	Cap-Spring
11B 1-1303001-01	Spindle	27D 1-1504013	Nut-Hex M12x1.5-8
12B 1-BRG80204GB278	Bearing-Ball	28D 1-1302001-00050B	Head w/Pointer and Trim
1C 1-CLP17GB894D1B	Ring- Retaining	36D 1-1502014	Clamp-Cord
2C 1-BRG80203GB278	Bearing-Ball 25mm	37D 1-1502003	Support-Motor Bracket
3C 1-1302023	Spacer-Bearing	38D 1-M8X20GB5781B	Screw-Hex HD M8
4C 1-1305011	Belt-"V" M24	39D 1-WSH8GB97D1B	Washer 8x16x1.6
5C 1-1302025	Nut-Pulley	40D 1-1502007-00001Y	Mount-Motor
6C 1-1305009-02001G	Pulley-Spindle	41D 2-U23182300-412	Cord-Motor
7C 1-1302022	Insert-Pulley	42D 1-M8GB6170B	Nut-Hex M8x1.25
8C 1-1305000-00049W	Guard-Pulley w/Labels	43D 1-G8812624-00001G	Motor
9C 1-M6X12GB9074D1Z	Screw-RD HD Washer	44D 1-M12GB6170B	Nut-Hex M12x1.75
10C 1-M8X16GB80B	Screw-Set M10x1.5-12	45D 1-WSH12GB93B	Lock Washer 1/2
11C 1-1505005-00001G	Pulley-Motor	46D 1-1502003	Support-Motor Bracket
12C 1-1505008-00001S	Knob	47D 1-M8X16GB5781B	Screw Hex HD M8
13C 1-M5X12GB818B	Screw-Pan HD M5x0.8-12	48D 1-1502006	Lever-Adjusting

# Notes

## Warranty

# RIKON

## POWER TOOLS

### 2-Year Limited Warranty

RIKON Power Tools/Richen Enterprise, Inc. ("Seller") warrants to only the original retail consumer/purchaser of our products that each product be free from defects in materials and workmanship for a period of two (2) years from the date the product was purchased at retail. This warranty may not be transferred.

This warranty does not apply to defects due directly or indirectly to misuse, abuse, negligence, accidents, repairs, alterations, lack of maintenance or normal wear and tear. Under no circumstances will Seller be liable for incidental or consequential damages resulting from defective products. All other warranties, expressed or implied, whether of merchantability, fitness for purpose, or otherwise are expressly disclaimed by Seller. This warranty does not cover products used for commercial, industrial or educational purposes.

This limited warranty does not apply to accessory items such as blades, drill bits, sanding discs or belts and other related items.

Seller shall in no event be liable for death, injuries to persons or property, or for incidental, contingent, special, or consequential damages arising from the use of our products.

To take advantage of this warranty proof of purchase documentation, which includes date of purchase and an explanation of the complaint, must be provided.

The Seller reserves the right to effect at any time, without prior notice, those alterations to parts, fittings, and accessory equipment which they may deem necessary for any reason whatsoever.

To take advantage of this warranty, please fill out the enclosed warranty card and send it to:  
RIKON Warranty  
110 Cummings Park  
Woburn, MA 01801

The card must be entirely completed in order for it to be valid. If you have any questions please contact us at 877-884-5167 or [warranty@rikontools.com](mailto:warranty@rikontools.com).

# **RIKON** **POWER TOOLS**

**For more information:  
110 Cummings Park  
Woburn, MA 01801**

**877-884-5167/781-933-8400  
info@rikontools.com  
www.rikontools.com**