

# 8" Benchtop Drill Press



## Operator's Manual

Record the serial number and date of purchase in your manual for future reference.

Serial Number: \_\_\_\_\_ Date of purchase: \_\_\_\_\_

For technical support or parts questions, email [techsupport@rikontools.com](mailto:techsupport@rikontools.com) or call toll free at (877)884-5167









# Safety Warnings

**IMPORTANT!** Safety is the single most important consideration in the operation of this equipment. **The following instructions must be followed at all times.**

There are certain applications for which this tool was designed. We strongly recommend that this tool not be modified and/or used for any other application other than that for which it was designed. If you have any questions about its application, do not use the tool until you have contacted us and we have advised you.

## General Safety Warnings

**KNOW YOUR POWER TOOL.** Read the owner's manual carefully. Learn the tool's applications, work capabilities, and its specific potential hazards.

	<p><b>⚠ DANGER</b> <b>ALWAYS GROUND ALL TOOLS.</b> If your tool is equipped with a three-pronged plug, you must plug it into a three-hole electric receptacle. If you use an adapter to accommodate a two-pronged receptacle, you must attach the adapter plug to a known ground. Never remove the third prong of the plug.</p> <p><b>ALWAYS AVOID DANGEROUS ENVIRONMENTS.</b> Never use power tools in damp or wet locations. Keep your work area well lighted and clear of clutter.</p>
	<p><b>⚠ DANGER</b> <b>ALWAYS REMOVE THE ADJUSTING KEYS AND WRENCHES FROM TOOLS AFTER USE.</b> Form the habit of checking to see that keys and adjusting wrenches are removed from the tool before turning it on.</p> <p><b>ALWAYS KEEP YOUR WORK AREA CLEAN.</b> Cluttered areas and benches invite accidents.</p>
	<p><b>⚠ DANGER</b> <b>ALWAYS KEEP VISITORS AWAY FROM RUNNING MACHINES.</b> All visitors should be kept a safe distance from the work area.</p> <p><b>ALWAYS MAKE THE WORKSHOP CHILDPROOF.</b> Childproof with padlocks, master switches, or by removing starter keys.</p>
	<p><b>⚠ DANGER</b> <b>NEVER OPERATE A TOOL WHILE UNDER THE INFLUENCE OF DRUGS, MEDICATION, OR ALCOHOL.</b></p>
	<p><b>⚠ DANGER</b> <b>ALWAYS WEAR PROPER APPAREL.</b> Never wear loose clothing or jewelry that might get caught in moving parts. Rubber-soled footwear is recommended for the best footing.</p>
	<p><b>⚠ DANGER</b> <b>ALWAYS USE SAFETY GLASSES AND WEAR HEARING PROTECTION.</b> Also use a face or dust mask if the cutting operation is dusty.</p>
	<p><b>⚠ DANGER</b> <b>NEVER OVERREACH.</b> Keep your proper footing and balance at all times.</p>
	<p><b>⚠ DANGER</b> <b>NEVER STAND ON TOOLS.</b> Serious injury could occur if the tool is tipped or if the cutting tool is accidentally</p>

**⚠ DANGER****ALWAYS DISCONNECT TOOLS.**

Disconnect tools before servicing and when changing accessories such as blades, bits, and cutters.

**ALWAYS AVOID ACCIDENTAL STARTING.**

Make sure switch is in "OFF" position before plugging in cord.

**NEVER LEAVE TOOLS RUNNING UNATTENDED.****⚠ DANGER****ALWAYS CHECK FOR DAMAGED PARTS.**

Before initial or continual use of the tool, a guard or other part that is damaged should be checked to assure that it will operate properly and perform its intended function. Check for alignment of moving parts, binding of moving parts, breakage of parts, mounting, and any other conditions that may affect its operation. A guard or other damaged parts should immediately be properly repaired or replaced.



### Special Safety Rules For Drill Presses

1. Do Not operate the Drill Press until it is assembled and you have read the instructions.
2. Do not operate the Drill Press unless you are familiar with its safe operation. If you are not familiar with the operation of a Drill Press seek advice from your supervisor, instructor or other qualified individual.
3. If you are using a bench top Drill Press, it must be securely fastened to a stand or bench.
4. If you are operating a floor Drill Press it must be securely fastened to the floor.
5. Always clear the table and work area before turning on the Drill Press.
6. Always use drill bits, cutting tools and accessories with a 1/2" shank or less.
7. Never place hands near the drill bit, cutting tool or accessory.
8. Never wear loose clothing, gloves or ties while operating the Drill Press.
9. Always have a firm footing while operating the Drill Press.
10. Always keep work surface and work areas clear of debris.
11. Never attempt to do set-up work, assembly or layout work on the Drill Press while it is in operation.
12. Never start the Drill Press with the drill bit, cutting tool or accessory in contact with the work-piece.
13. Always lock all table, column and head locks before turning on the Drill Press.
14. Never operate the Drill Press with a damaged drill bit, cutting tool or accessory.
15. Always check the drill bit, cutting tool or accessory in tight in the chuck.
16. Never operate the Drill Press with the chuck key in the chuck.
17. Always adjust the depth stop to avoid drilling into the table surface.
18. Never drill material unless it is properly supported. Non flat work-pieces require additional support.
19. Always clamp the work piece to the table.
20. Always support large work-pieces at the same height as the table.
21. Never remove the work-piece or clear the table until the Drill Press comes to a complete stop.
22. Always wear a face shield and safety glasses while operating the Drill Press.
23. Never operate the Drill Press with missing, damaged, worn, loose or defective parts.
24. Never adjust, change speeds or perform maintenance on the Drill Press while it is operating.
25. Always clean the work surface and work area when finished operating the Drill Press.
26. Always disconnect the power when adjusting or performing maintenance on the Drill Press.
27. Always disconnect the power when finished using the Drill Press to prevent accidental operation.

### California Proposition 65 Warning

**WARNING:** Some dust created by power sanding, sawing, grinding, drilling, and other construction activities contains chemicals known to the State of California to cause cancer and birth defects or other reproductive harm. Your risk from exposure to these chemicals varies, depending on how often you do this type of work. To reduce your exposure, work in a well-ventilated area and with approved safety equipment, such as dust masks that are specially designed to filter out microscopic particles.

For more detailed information about California Propostion 65 log onto [rikontools.com](http://rikontools.com).

**SAVE THESE INSTRUCTIONS.**

**Refer to them often.**

## Table of Contents

Safety Warnings.....	2-3
Special Safety Rules For Drill Presses.....	3
Specifications.....	4
Unpacking and Contents.....	5
Getting to Know Your Drill Press.....	6
Assembly.....	7-9
Adjustments.....	9-10
Troubleshooting.....	11
Notes.....	12
Wiring Diagram.....	12
Electrical Requirements.....	13
Explosion Diagrams/Parts Lists.....	14-21
Warranty.....	22
Notes.....	23

## Specifications

<b>Model No.</b>	<b>30-100</b>
<b>Specifications</b>	
Type	Bench
Horsepower	1/3 HP
Amps	2.5
Volts	120V, 60 Hz
RPM	1,720
Speed Range (RPM)	620 - 3,100
Speeds	5
Chuck Size	1/2"
Chuck Taper	JT33
Drilling Capacity	1/2"
Spindle Travel	2"
Spindle Taper	JT33
Quill Diameter	1-1/2"
<b>Overall</b>	
Table	6-5/8" x 6-3/8"
Table Tilts	45°
Table Rotates	360°
Maximum Chuck to Table	7-1/16"
Maximum Chuck to Base	10-1/4"
Column Diameter	1-7/8"
Height	22-3/4"
Base Size	11" x 7-1/8"
Net Weight	32 lbs.
Shipping Weight	36 lbs.
Shipping Carton	18" x 9-1/4" x 13-1/4"
<b>Warranty</b>	<b>5 Years</b>

# Contents of Package

## Unpacking and Checking Contents

Unpack your drill press from its carton and check to see that you have all of the following items. Set packing material and shipping carton to the side. **Do not discard** until machine has been set up and is running properly.

Do not turn your machine ON if any of these items are missing. You may cause injury to yourself or damage to your machine. If parts are missing contact RIKON customer service at 877-884-5167 or [techsupport@rikontools.com](mailto:techsupport@rikontools.com).

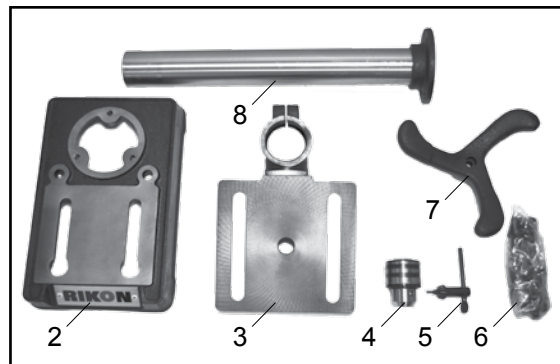
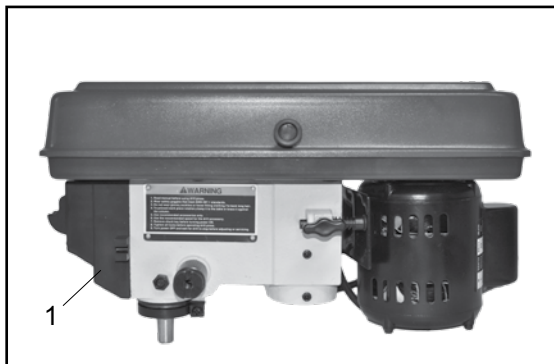

### Item Description

- 1 Drill Press Head
- 2 Base
- 3 Table
- 4 1/2" Chuck
- 5 Chuck Key
- 6 Hardware Bag (See Contents Below)
- 7 Feed Handle
- 8 Column

### Item Description

- 9 Table Lock Handle
- 10 Column Mounting Bolts
- 11 3mm Hex Wrench
- 12 4mm Hex Wrench
- 13 6mm Hex Wrench
- 14 Feed Handle Bolt
- 15 Owner's Manual

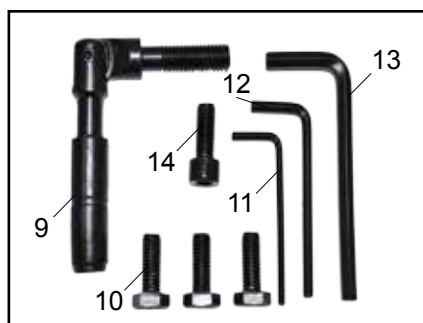

## Getting to Know Your Drill Press

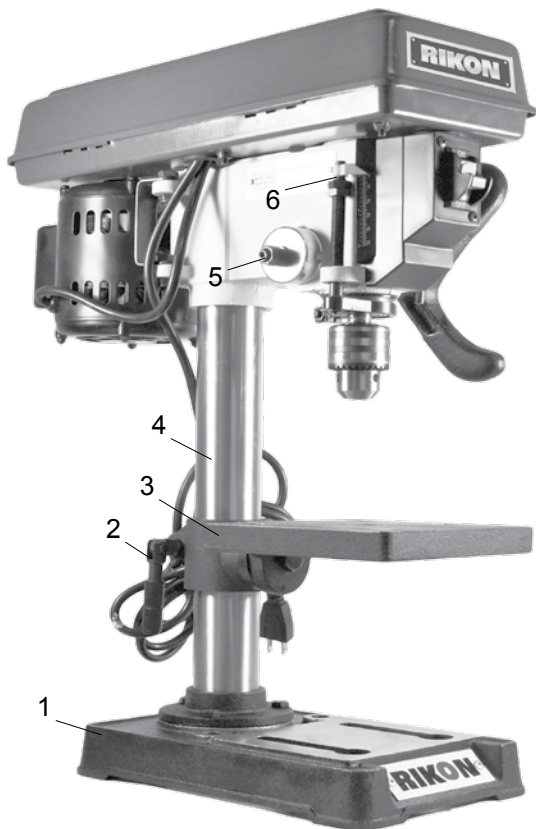

Item	Description
1	Base
2	Table Lock Handle
3	Table
4	Column Support Tube
5	Handle Return Spring
6	Depth Stop

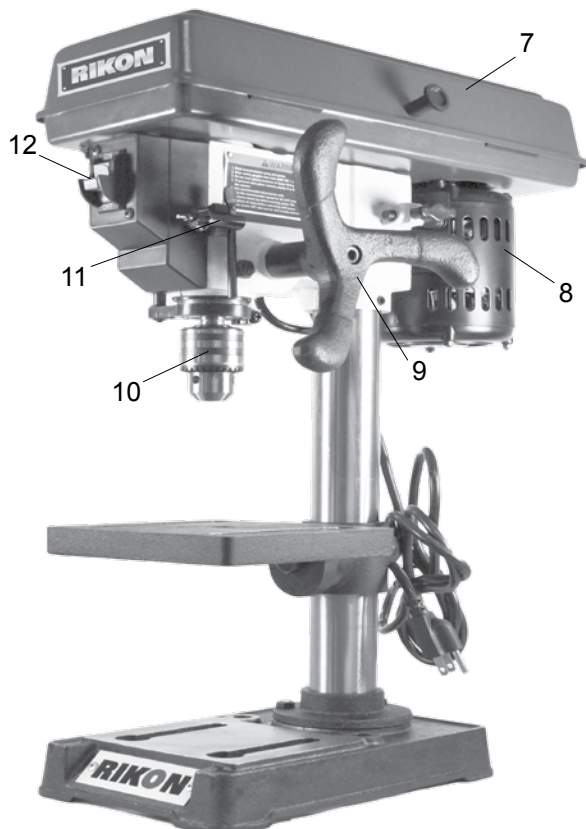



Item	Description
7	Belt Cover
8	Motor
9	Feed Handle
10	Chuck
11	Chuck Key Holder
12	Switch

# Assembly

The machine must not be plugged in and the power switch must be in the OFF position until assembly is complete.

## Tools Required for Assembly

Item	Description
	Phillips Screwdriver
	Adjustable or 13mm Wrench

## Unpacking and Clean-up

1. Carefully finish removing all contents from shipping carton. Compare contents of the shipping carton with the list shown on page 5. Place parts on a protected surface.
2. Report any shipping damage to your local distributor. If parts are missing contact RIKON customer service at 877-884-5167 or [techsupport@rikontools.com](mailto:techsupport@rikontools.com).
3. Clean all rust protected surfaces. **Do not use**; gasoline, paint thinner, mineral spirits, etc. These may damage painted surfaces.
4. Set packing material and shipping carton to the side. **Do not discard** until machine has been set up and is running properly.

1. Install the column to the base using the three column mounting bolts. (Fig.01)



Fig.01

2. Next install the table lock handle through the unthreaded hole on the left of the table support casting. The handle should engage the thread on the right side of the table support casting. (Fig.02)



Fig.02

## Assembly

3. Slide the drill press head over the column.  
(Fig.03)



**Fig.03**

4. Center the drill press head over the table and base. Tighten the drill press head into position by locking the two hex screws on the side of the casting. (A-Fig.04)

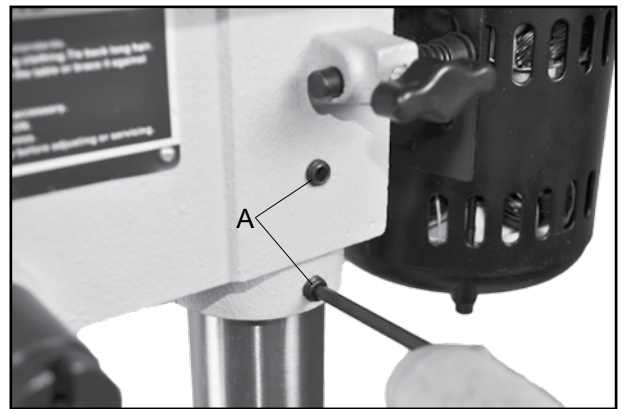

**Fig.04**

5. Next, slide the 1/2" chuck (A-Fig.05) over the pre-installed spindle (B-Fig.05). Open the chuck jaws fully and tap into place using a rubber mallet or a hammer and block of wood.

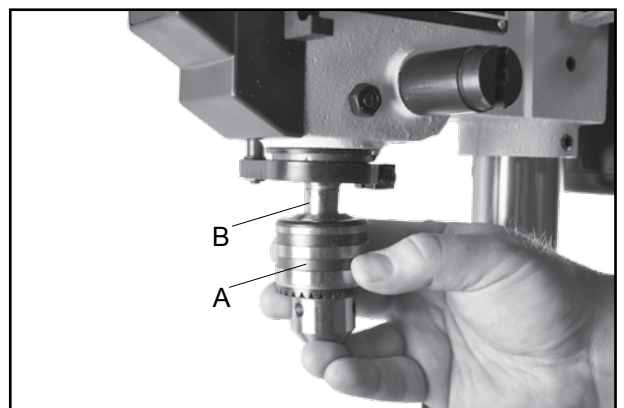

**Fig.05**



## Assembly

6. The feed handle (A-Fig.06) is secured to the feed shaft with the supplied Allen bolt (B-Fig.06).

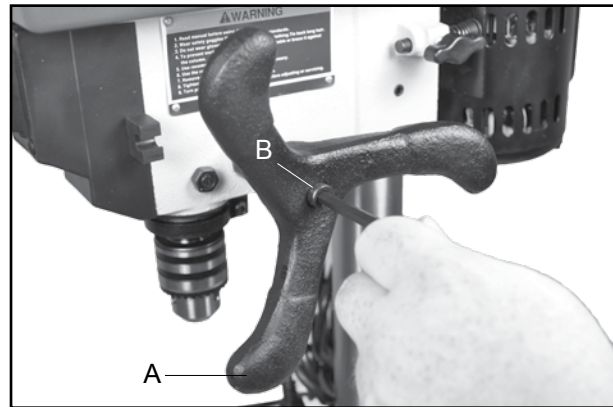

Fig.06

## Adjustments

7. Depth Stop: The depth stop and scale are found on the left side of the switch box. To adjust, lower the drill chuck until pointer shows desired depth on the scale. Loosen the lower nut on the threaded shaft (A-Fig.07) until it bottoms out on the head casting (B-Fig.07). Tighten upper nut against the lower nut to retain the adjustment.

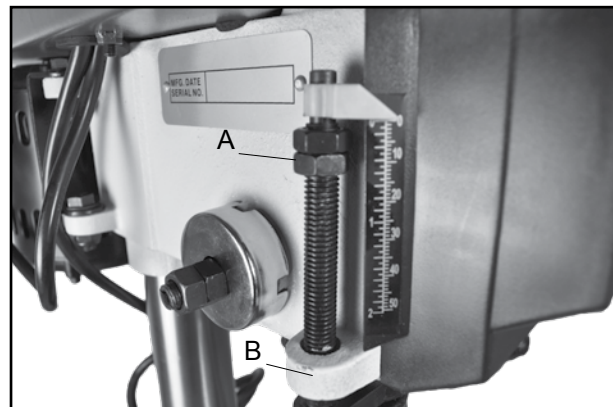

Fig.07

8. Table Tilt: The drill press table will tilt 0-45 degrees left and right. To tilt, loosen the nut located under the table (A-Fig.08). Align the "zero" mark on the table (B-Fig.08) to the desired degree marking on the scale. Tighten the nut under the table to retain the adjustment.

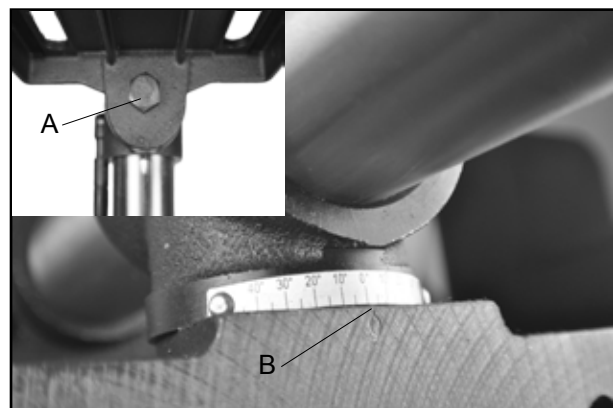
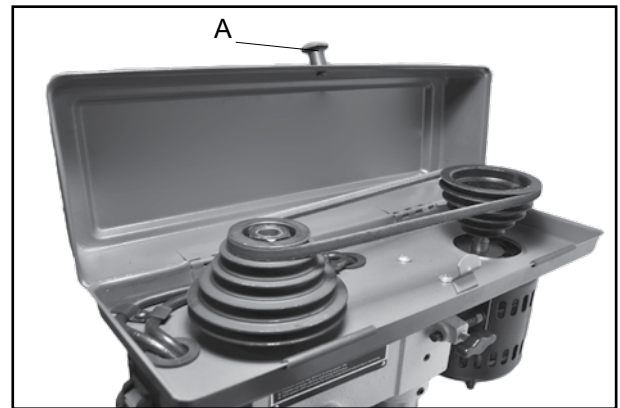

Fig.08

## Adjustments

9. Changing Spindle Speed: The 30-100 Bench Drill Press has five spindle speeds. To change, lift the cover with the handle (A-Fig.09).



**Fig.09**

10. Loosen the motor lock knob (A-Fig.10). Move the motor (B-Fig.10) manually toward the feed handle to take tension off of the belt.

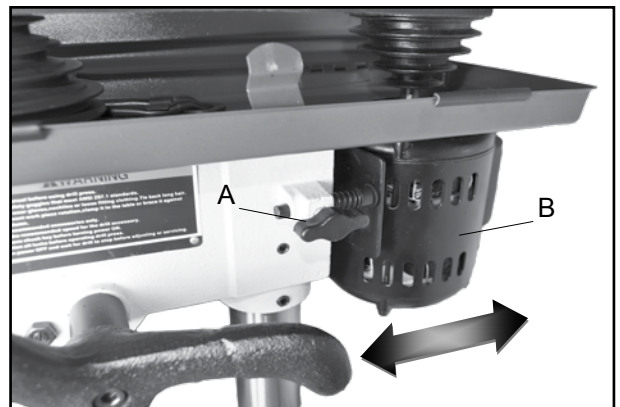

**Fig.10**

11. Move the drive belt to the desired speed position, refer to speed chart inside belt cover. Manually move the motor away from the feed handle until the belt is tensioned, tighten motor lock knob. The belt is properly tensioned when the deflection distance is 1/2" when pushed by hand (Fig.11).

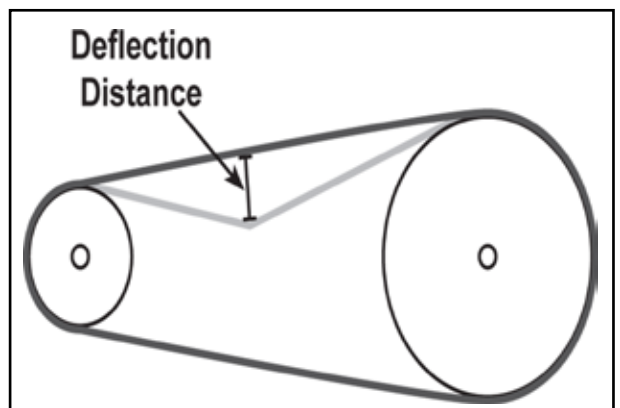

**Fig.11**

# Troubleshooting

Problem	Possible Causes	Likely Solutions
Tool will not start.	<ol style="list-style-type: none"> <li>1. Cord not connected.</li> <li>2. No power at outlet.</li> <li>3. Internal damage or wear.</li> </ol>	<ol style="list-style-type: none"> <li>1. Check that cord is plugged in.</li> <li>2. Check power at outlet. If outlet is unpowered, turn off tool and check circuit breaker. If breaker is tripped, make sure circuit is right capacity for tool and circuit has no other loads.</li> <li>3. Have technician service tool.</li> </ol>
Tool operates slowly.	Extension cord too long or wire size too small.	Eliminate use of extension cord. If an extension cord is needed, use shorter/heavier gauge cord. See <i>Extension Cords</i> in <i>GROUNDING</i> section.
Performance decreases over time.	<ol style="list-style-type: none"> <li>1. Accessory dull or damaged.</li> <li>2. Carbon brushes worn or damaged.</li> </ol>	<ol style="list-style-type: none"> <li>1. Keep cutting accessories sharp. Replace as needed.</li> <li>2. Have qualified technician replace brushes.</li> </ol>
Excessive noise or rattling.	<ol style="list-style-type: none"> <li>1. Belt too loose (slipping) or too tight (bearing damage).</li> <li>2. Spindle dry</li> <li>3. Loose spindle pulley</li> <li>4. Loose motor pulley</li> <li>5. Internal damage or wear.</li> </ol>	<ol style="list-style-type: none"> <li>1. Properly tension belt.</li> <li>2. Lubricate spindle</li> <li>3. Check pulley nut</li> <li>4. Tighten Set screws</li> <li>5. Have technician service tool.</li> </ol>
Overheating.	<ol style="list-style-type: none"> <li>1. Forcing machine to work too fast.</li> <li>2. Accessory misaligned.</li> <li>3. Accessory dull or damaged.</li> <li>4. Blocked motor housing vents.</li> <li>5. Motor being strained by long or small diameter extension cord.</li> </ol>	<ol style="list-style-type: none"> <li>1. Allow machine to work at its own rate.</li> <li>2. Check and correct accessory to table alignment.</li> <li>3. Keep cutting accessories sharp. Replace as needed.</li> <li>4. Wear ANSI-approved safety goggles and NIOSH-approved dust mask/respirator while blowing dust out of motor using compressed air.</li> <li>5. Eliminate use of extension cord. If an extension cord is needed, use one with the proper diameter for its length and load. See <i>Extension Cords</i> in <i>GROUNDING</i> section.</li> </ol>
Drill bit burns or smokes	<ol style="list-style-type: none"> <li>1. Incorrect spindle speed</li> <li>2. Dull drill bit</li> <li>3. Drilling too slowly</li> <li>4. Lacking lubrication</li> </ol>	<ol style="list-style-type: none"> <li>1. Change spindle speed</li> <li>2. Replace with new bit</li> <li>3. Drill faster</li> <li>4. Lubricate cutting area</li> </ol>
Drill bit wobbles	<ol style="list-style-type: none"> <li>1. Bent bit</li> <li>2. Worn Spindle Bearings</li> <li>3. Drill bit not in Chuck correctly</li> <li>4. Chuck not properly installed</li> </ol>	<ol style="list-style-type: none"> <li>1. Replace drill bit</li> <li>2. Replace spindle bearings</li> <li>3. Reinstall drill bit</li> <li>4. Reinstall Chuck and Arbor assembly</li> </ol>
Feed Wheel returns slowly, or too fast	Tension Spring not in adjustment	Adjust Tension Spring.
Drill bit binds	<ol style="list-style-type: none"> <li>1. Workpiece pinching drill bit</li> <li>2. Dull drill bit</li> <li>3. Feed pressure too hard</li> <li>4. Belts loose</li> </ol>	<ol style="list-style-type: none"> <li>1. Reposition workpiece, lubricate drill</li> <li>2. Replace drill bit</li> <li>3. Pull Feed Handle slowly.</li> <li>4. Adjust motor and spindle belt tension</li> </ol>



**Follow all safety precautions whenever diagnosing or servicing the tool. Disconnect power supply before service.**

## Notes

Use this section to record maintenance, service and any calls to Technical Support:

## Wiring Diagram

**WARNING:** This machine must be grounded.

Replacement of the power supply cable should only be done by a qualified electrician.

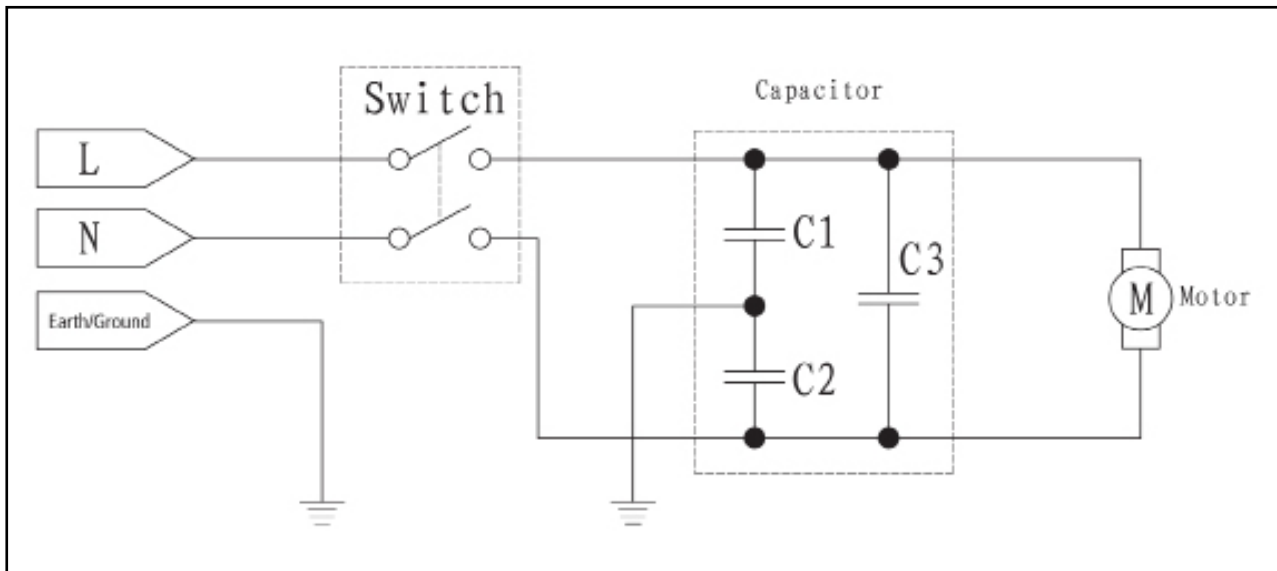

## Electrical Requirements

In the event of a malfunction or breakdown, grounding provides a path of least resistance for electric current to reduce the risk of electric shock. This tool is equipped with an electric cord having an equipment-grounding conductor and a grounding plug. The plug must be plugged into a matching outlet that is properly installed and grounded in accordance with all local codes and ordinances.

Do not modify the plug provided. If it will not fit the outlet, have the proper outlet installed by a qualified electrician.

Improper connection of the equipment-grounding conductor can result in a risk of electric shock. The conductor, with insulation having an outer surface that is green with or without yellow stripes, is the equipment-grounding conductor. If repair or replacement of the electric cord or plug is necessary, do not connect the equipment-grounding conductor to a live terminal.

Check with a qualified electrician or service personnel if the grounding instructions are not completely understood, or if in doubt as to whether the tool is properly grounded.

Use only three wire extension cords that have three-prong grounding plugs and three-pole receptacles that accept the tool's plug.\*

Repair or replace a damaged or worn cord immediately.

This tool is intended for use on a circuit that has an outlet that looks the one illustrated in Figure A below. The tool has a grounding plug that looks like the grounding plug as illustrated in Figure A below. A temporary adapter, which looks like the adapter as illustrated in Figure B below, may be used to connect this plug to a two-pole receptacle, as shown in Figure B if a properly grounded outlet is not available.\*\* The temporary adapter should only be used until a properly grounded outlet can be installed by a qualified electrician. The green colored rigid ear or tab, extending from the adapter, must be connected to a permanent ground such as a properly grounded outlet box.

\* Canadian electrical codes require extension cords to be certified SJT type or better.

\*\* Use of an adapter in Canada is not acceptable.

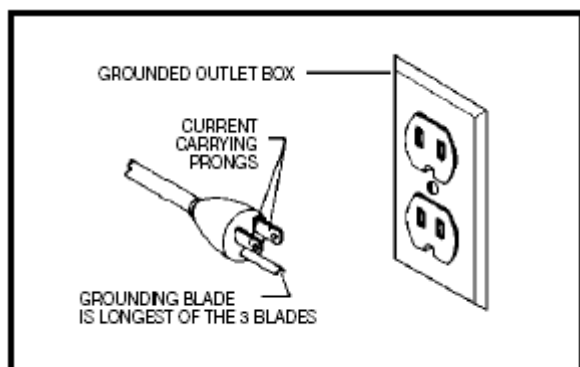

Fig. A

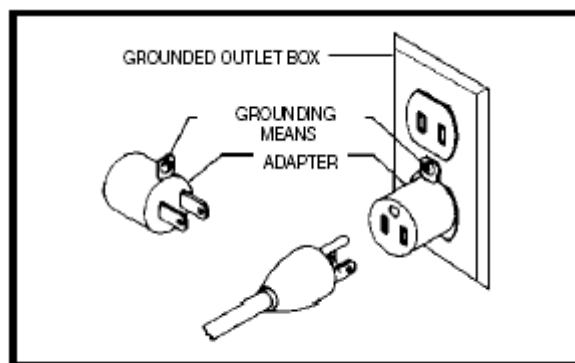
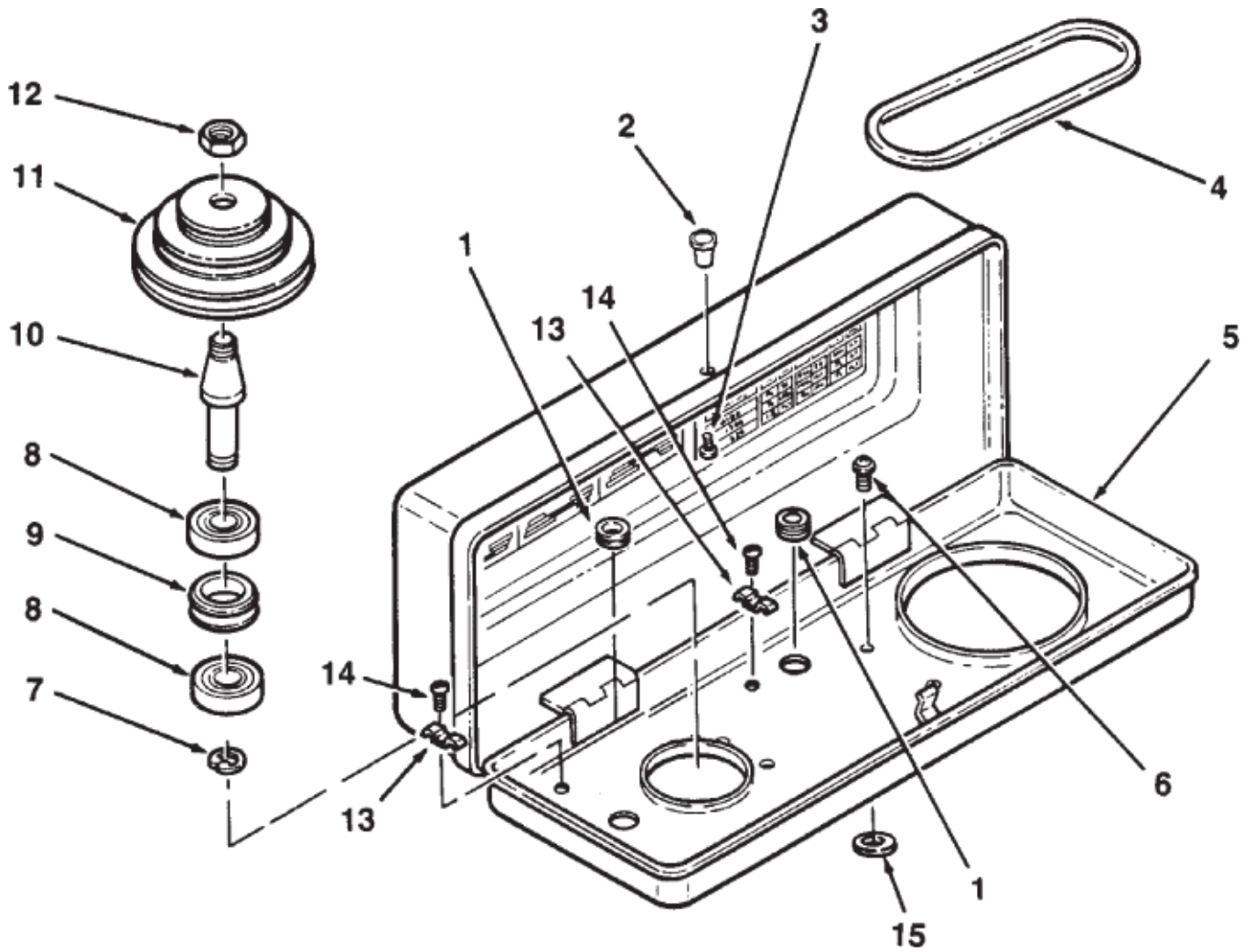

Fig. B

# Explosion Diagram



## Parts List

<b>KEY No.</b>	<b>Description</b>
30-100-1A	Bushing-Rubber
30-100-2A	Knob
30-100-3A	Screw-Pan Hd.M5x0.8-1.2
30-100-4A	Belt-"V" 5/16x26
30-100-5A	Guard w/Labels
30-100-6A	Screw-Washer Hd.
30-100-7A	Ring Retaining
30-100-8A	Bearing-Ball 17mm
30-100-9A	Spacer
30-100-10A	Insert-Pulley
30-100-11A	Pulley-Spindle
30-100-12A	Nut-Pulley
30-100-13A	Clamp Cord
30-100-14A	Screw-Pan Hd.M5x.08-16
30-100-15A	Washer,Foam

# Explosion Diagram

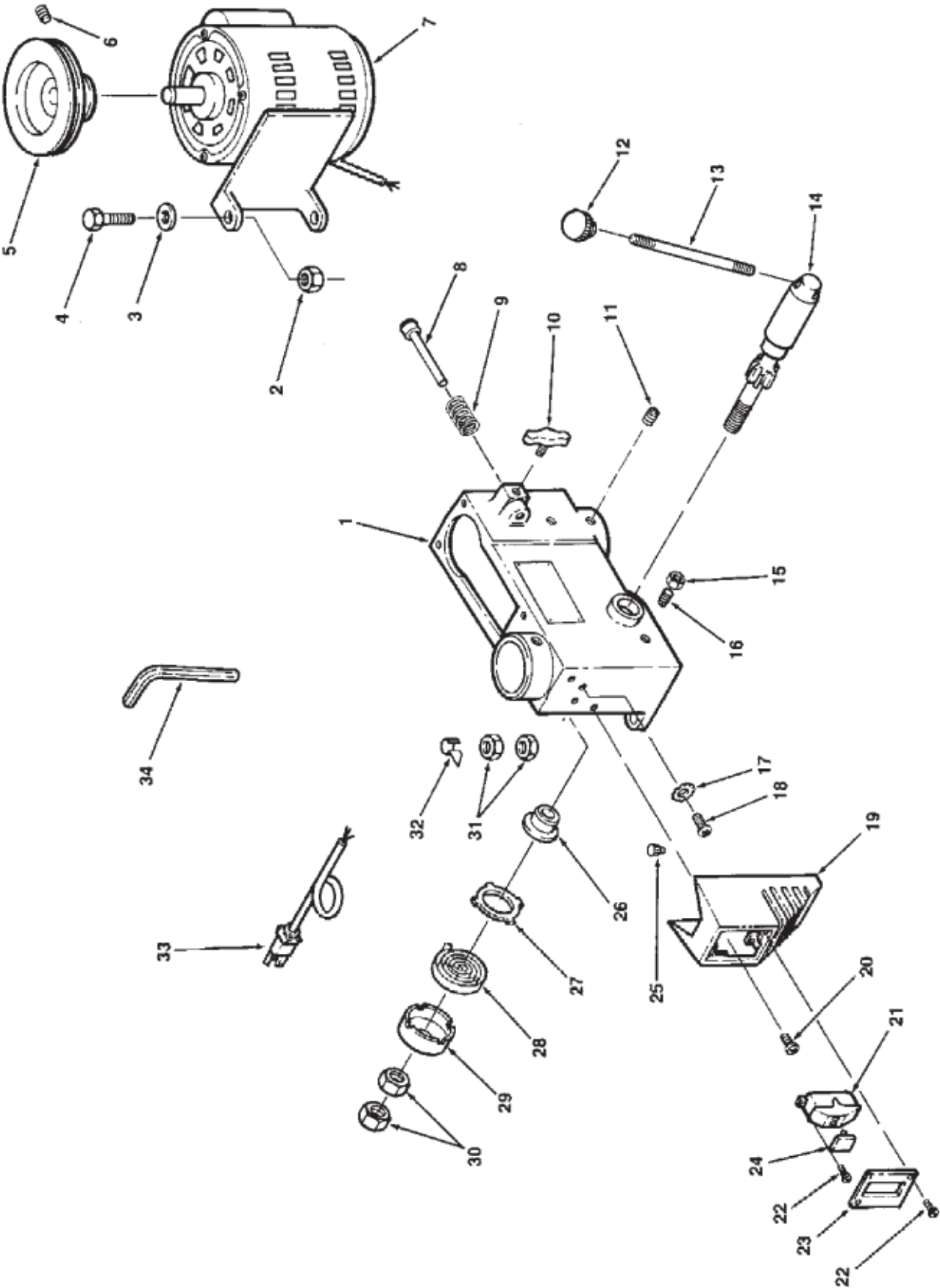



## Parts List

<b>KEY No.</b>	<b>Description</b>
30-100-1B	Head w/Roll Pin & Trim
30-100-2B	Nut-Lock M8x1.25-8
30-100-3B	Washer 8MM
30-100-4B	Screw-Hex M8x1.25-25
30-100-5B	Pulley-Motor
30-100-6B	Screw-Hex Soc. Set M8x1.25-8
30-100-7B	Motor
30-100-8B	Stop-Motor
30-100-9B	Spring-Motor Stop
30-100-10B	Knob-Motor Adjusting
30-100-11B	Screw-Hex Soc. Set M8x1.25-8
30-100-12B	Knob
30-100-14B	Shaft-Pinion
30-100-15B	Nut-Hex M8x1.25
30-100-16B	Screw-Fit.Sit.Set M8x1.25
30-100-17B	Lockwasher-Ext.5mm
30-100-18B	Screw-Pan Hd. M5x0.8-8
30-100-19B	Box-Switch w/Depth Scale
30-100-20B	Screw-Pan Cr.. M5x0.8-12
30-100-21B	Switch-Locking
30-100-22B	Screw-Self Tapping Pan
30-100-23B	Cover-Switch Plate
30-100-24B	Key-Switch
30-100-25B	Connector-Wire
30-100-26B	Seat-Spring
30-100-27B	Retainer-Spring
30-100-28B	Spring-Tension
30-100-29B	Cap-Spring
30-100-30B	Nut-Hex 3/8-24
30-100-31B	Nut Hex M10x1.5
30-100-32B	Pointer
30-100-33B	Cord-Power

# Explosion Diagram

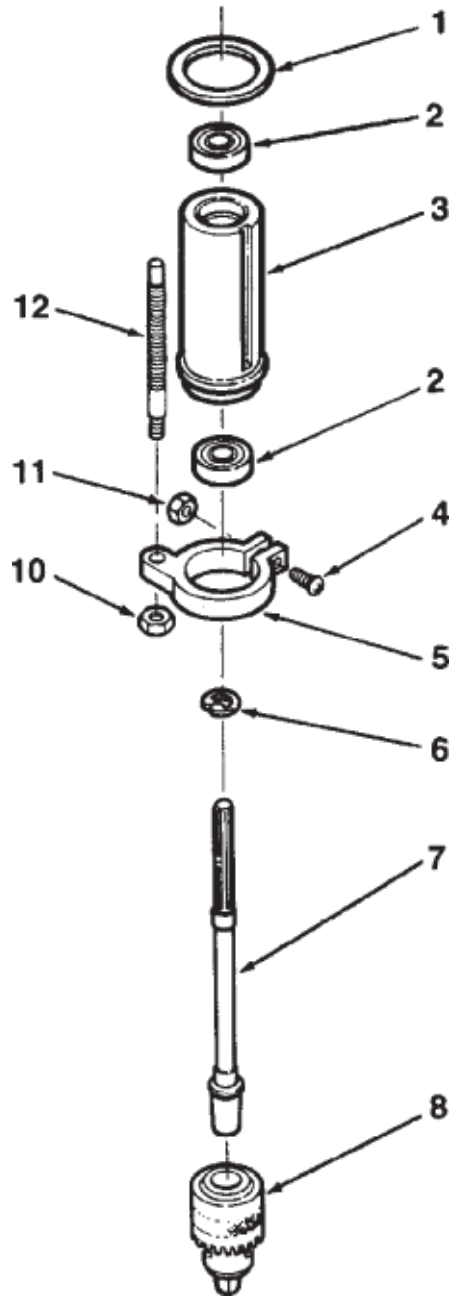

## Parts List

<b>KEY No.</b>	<b>Description</b>
30-100-1C	Gasket-Quill
30-100-2C	Bearing-Ball 12mm
30-100-3C	Tube-Quill
30-100-4C	Screw-Pan M5x0.8-20
30-100-5C	Collar-Stop
30-100-6C	Ring Retaining
30-100-7C	Shaft-Spindle
30-100-8C	Chuck
30-100-9C	Key-Chuck
30-100-10C	Nut-Hex M6x1.0
30-100-11C	Nut-Hex M5x.08
30-100-12C	Rod-Stop

# Explosion Diagram

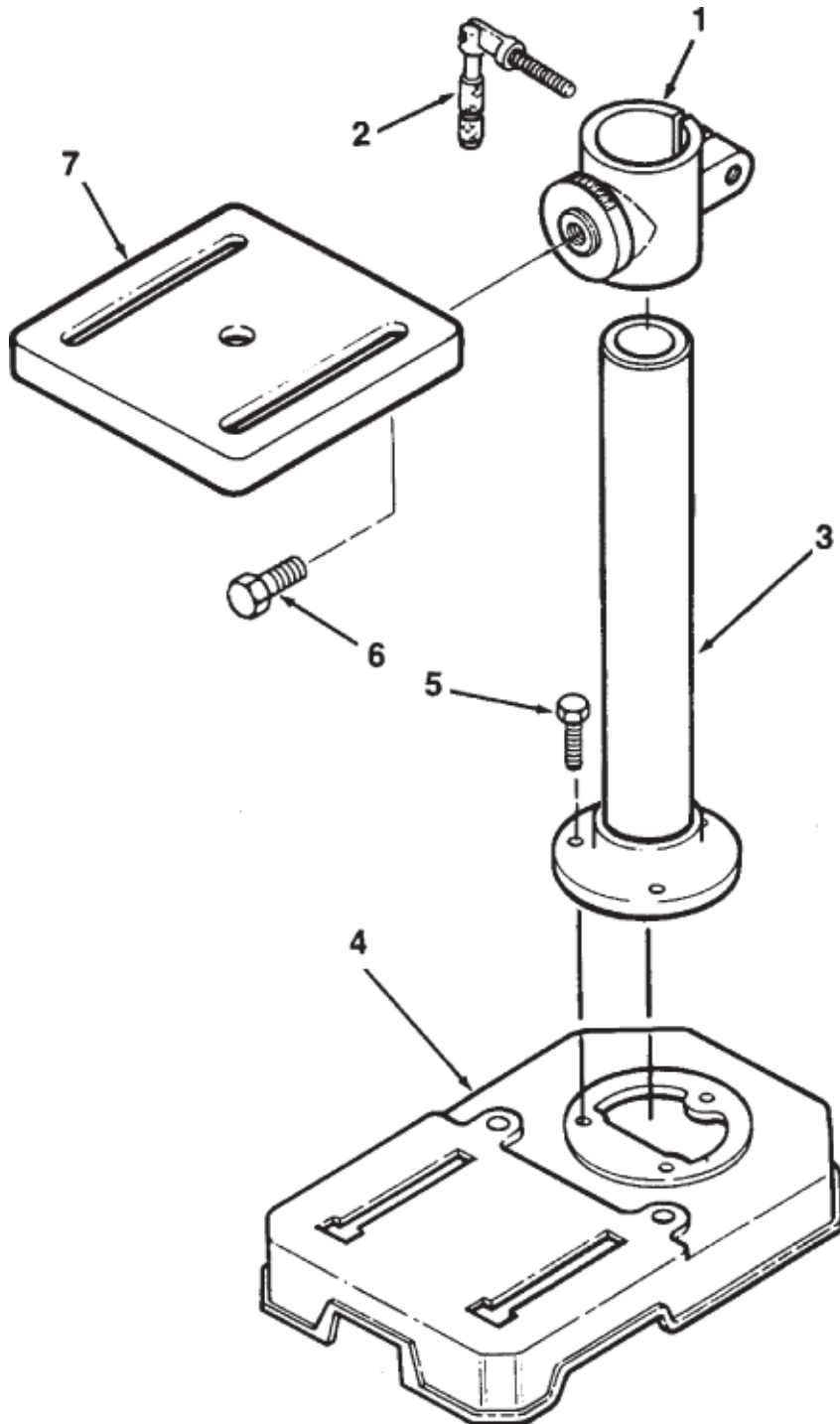

## Parts List

<b>KEY No.</b>	<b>Description</b>
30-100-1D	Support-Table w/Scale
30-100-2D	Support-Lock Handle
30-100-3D	Tube/Support
30-100-4D	Base
30-100-5D	Screw-Hex Hd. M8x1.25-20
30-100-6D	Screw-Hex Hd. 1/2-12x7/8
30-100-7D	Table

## Warranty

# RIKON POWER TOOLS

### 5-Year Limited Warranty

RIKON Power Tools Inc. (“Seller”) warrants to only the original retail consumer/purchaser of our products that each product be free from defects in materials and workmanship for a period of five (5) years from the date the product was purchased at retail. This warranty may not be transferred.

This warranty does not apply to defects due directly or indirectly to misuse, abuse, negligence, accidents, repairs, alterations, lack of maintenance or normal wear and tear. Under no circumstances will Seller be liable for incidental or consequential damages resulting from defective products. All other warranties, expressed or implied, whether of merchantability, fitness for purpose, or otherwise are expressly disclaimed by Seller. This warranty does not cover products used for commercial, industrial or educational purposes.

This limited warranty does not apply to accessory items such as blades, drill bits, sanding discs or belts and other related items.

Seller shall in no event be liable for death, injuries to persons or property, or for incidental, contingent, special, or consequential damages arising from the use of our products.

To take advantage of this warranty proof of purchase documentation, which includes date of purchase and an explanation of the complaint, must be provided.

The Seller reserves the right to effect at any time, without prior notice, those alterations to parts, fittings, and accessory equipment which they may deem necessary for any reason whatsoever.

To take advantage of this warranty, please fill out the enclosed warranty card and send it to:  
RIKON Warranty  
16 Progress Rd.  
Billerica, MA 01821

The card must be entirely completed in order for it to be valid. If you have any questions please contact us at 877-884-5167 or [warranty@rikontools.com](mailto:warranty@rikontools.com).

## Notes



**For more information:**

**16 Progress Rd  
Billerica, MA 01821**

**877-884-5167 / 978-528-5380  
techsupport@rikontools.com  
www.rikontools.com**

