

16" VS Scroll Saw



Operator's Manual

Record the serial number and date of purchase in your manual for future reference.

Serial Number: _____ Date of purchase: _____

For technical support or parts questions, email techsupport@rikontools.com or call toll free at (877)884-5167







Operator Safety: Required Reading

IMPORTANT! Safety is the single most important consideration in the operation of this equipment. The following instructions must be followed at all times.

There are certain applications for which this tool was designed. We strongly recommend that this tool not be modified and/or used for any other application other than that for which it was designed. If you have any questions about its application, do not use the tool until you have contacted us and we have advised you.

General Safety Warnings

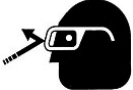
KNOW YOUR POWER TOOL. Read the owner's manual carefully. Learn the tool's applications, work capabilities, and its specific potential hazards.

	<p>⚠ DANGER ALWAYS GROUND ALL TOOLS. If your tool is equipped with a three-pronged plug, you must plug it into a three-hole electric receptacle. If you use an adapter to accommodate a two-pronged receptacle, you must attach the adapter plug to a known ground. Never remove the third prong of the plug.</p> <p>ALWAYS AVOID DANGEROUS ENVIRONMENTS. Never use power tools in damp or wet locations. Keep your work area well lighted and clear of clutter.</p>
	<p>⚠ DANGER ALWAYS REMOVE THE ADJUSTING KEYS AND WRENCHES FROM TOOLS AFTER USE. Form the habit of checking to see that keys and adjusting wrenches are removed from the tool before turning it on.</p> <p>ALWAYS KEEP YOUR WORK AREA CLEAN. Cluttered areas and benches invite accidents.</p>
	<p>⚠ DANGER ALWAYS KEEP VISITORS AWAY FROM RUNNING MACHINES. All visitors should be kept a safe distance from the work area.</p> <p>ALWAYS MAKE THE WORKSHOP CHILDPROOF. Childproof with padlocks, master switches, or by removing starter keys.</p>
	<p>⚠ DANGER NEVER OPERATE A TOOL WHILE UNDER THE INFLUENCE OF DRUGS, MEDICATION, OR ALCOHOL.</p>
	<p>⚠ DANGER ALWAYS WEAR PROPER APPAREL. Never wear loose clothing or jewelry that might get caught in moving parts. Rubber-soled footwear is recommended for the best footing.</p>
	<p>⚠ DANGER ALWAYS USE SAFETY GLASSES AND WEAR HEARING PROTECTION. Also use a face or dust mask if the cutting operation is dusty.</p>
	<p>⚠ DANGER NEVER OVERREACH. Keep your proper footing and balance at all times.</p>
	<p>⚠ DANGER NEVER STAND ON TOOLS. Serious injury could occur if the tool is tipped or if the cutting tool is accidentally contacted.</p>

⚠ DANGER**ALWAYS DISCONNECT TOOLS.**

Disconnect tools before servicing and when changing accessories such as blades, bits, and cutters.

**ALWAYS AVOID ACCIDENTAL STARTING.**

Make sure switch is in "OFF" position before plugging in cord.

NEVER LEAVE TOOLS RUNNING UNATTENDED.**⚠ DANGER****ALWAYS CHECK FOR DAMAGED PARTS.**

Before initial or continual use of the tool, a guard or other part that is damaged should be checked to assure that it will operate properly and perform its intended function. Check for alignment of moving parts, binding of moving parts, breakage of parts, mounting, and any other conditions that may affect its operation. A guard or other damaged parts should immediately be properly repaired or replaced.



Special Safety Rules For Scroll Saws

When using electric tools basic safety precautions should always followed to reduce the risk of fire, electric shock and personal injury. Read all these instructions before attempting to operate this product. Save these instructions for future reference.

- Keep work area clear. Cluttered areas and benches invite injuries.
- Consider work area environment. Do not expose tools to rain. Do not use tools in damp or wet locations. Keep work area well lit. Do not use tools in the presence to flammable liquids or gases.
- Guard against electric shock. Avoid body contact with grounded surfaces.
- Keep other people away. Do not let others, especially children, not involved in the work touch or the power cord and keep them away from the work area.
- Store idle tools. When not use, tools should be stored in a dry locked-up place, out of reach of children.
- Do not force the tool. It will do the job better and safer at the rate for which it was intended.
- Use the right tool. Do not force small tools to do the job of a heavy-duty tool. Do not use tools for purposes not intended; for example do not use circular saws to cut tree limbs or logs.
- Dress properly. Do not wear loose clothing or jewelry that can be caught in moving parts. On-skid footwear is recommended when working outdoors. Wear protective hair covering to contain long hair.
- Use protective equipment. Use safety glasses. Use face or dust mask if cutting operations create dust.
- Connect dust extraction equipment. If devices are provided for the connection of dust extraction and collecting equipment, ensure these are connected and properly used.
- Do not abuse the power cord. Never pull the power cord to disconnect it from the socket. Keep the lead away from heat, oil and sharp edge.
- Secure work. Where possible use clamps or a vice to hold the work. It's safer than using your hand.
- Don't over reach. Keep proper footing and balance at all time.
- Maintain tools with care. Keep cutting tools sharp and clean for better and safer performance. Follow instructions for lubricating and changing accessories. Inspect power cables periodically and if damaged have they replaced by an authorized service facility. Inspect extension cables periodically and replace if damaged. Keep handles dry-clean and free from oil and grease.
- Disconnect tools. When not in use, before servicing and when changing accessories such as blades, bits, cutters, Disconnect tools from the power supply.
- Remove adjusting keys and wrenches. Form the habit of checking to see that keys and adjusting wrenches are removed from the tool before turning it on.
- Avoid unintentional starting. Ensure switch is in 'off' position when plugging in.
- Use outdoor extension leads. When the tool is used outdoors, use only extension leads intended for outdoor use and so marked.
- Stay alert. Watch what you are doing, use common sense and do not operate the tool when you are tired.
- Check damaged parts. Before further use of the tools, it should be carefully checked to determine that it will operate properly and perform its intended function. Check the alignment of moving parts, binding of moving parts, breakage of parts, mounting and any other conditions that may affect its operation. A guard or other part that is damaged should be properly repaired or replaced by an authorized service center unless otherwise indicated in this instruction manual. Do not use the tool if the switch does not turn on and off.
- Warning. Repaired by a qualified person. This electric tool compliers with the relevant safety rules. Repairs should only be carried out by a qualified person using original spare parts; otherwise this may result in considerable danger to the user.

**SAVE THESE INSTRUCTIONS.
Refer to them often.**

Table of Contents

Safety Warnings.....	2-3
Sander Safety Rules	3
Specifications	4
Contents of Package	5
Assembly	6-8
Electrical Requirements	9
Operation.....	10-11
Maintenance	12
Changing the Motor Belt.....	12
Trouble Shooting.....	13
Wiring Diagram.....	13
Parts List	14
Parts Explosion.....	15
Notes	16
Warranty	17

Specifications

Model No.	10-600VS
Motor	
Amps	1.2
Volts	120V, 60 Hz
Electronic Variable Speed (SPM)	550 - 1,650
Cutting Capacity	
Blade Length	5"
Height	2"
Stroke	19/32"
Throat Depth	15-3/4"
Table	
Size	10-1/16" x 15-5/16"
Left Tilt	0° - 45°
Features	
Stroke Speed Per Minute	550 - 1,650
Dust Port Diameter	1-3/8"
Maximun Sound Level (Idle)	<76 dB
Overall	
Height	14-15/16"
Width	12-9/16"
Depth	29-3/4"
Base Size	9" x 15-1/2"
Net Weight	26.4 lbs.
Shipping Weight	30 lbs.
Shipping Carton	26" x 13" x 15-1/2"
Warranty	5 Years

Contents of Package

When unpacking, check to make sure the following parts are included. If any parts are missing or broken, please call RIKON Power Tools at the number on the cover of this manual as soon as possible.

Carton Contents

Item	Description	Qty
A	Pinless blade holder	2
B	Safety shield	1
C	Pinless blade	1

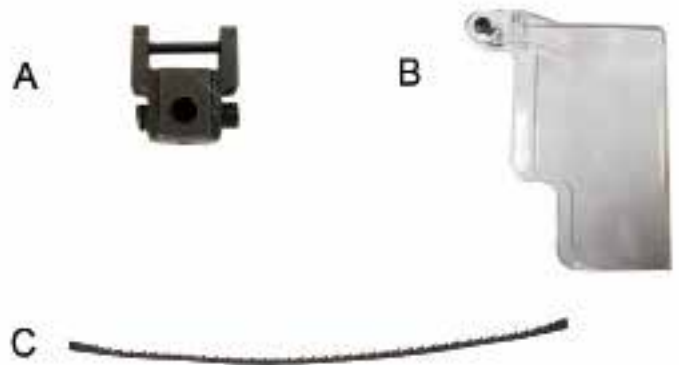

List of loose parts in bag

Description	Qty
 Hex nut M5	2
 Washer 5 mm	1
 Lock washer 5mm	1
 Screw M5X25	1
 L wrench	1

Assembly

SCROLL SAW DESIGN FEATURES

1. Clamping screw: for removing the saw blade.
2. Blade guard: protects your hands from injury.
3. Work piece holder
4. Shavings blower: keeps the work piece area free from dust.
5. Variable speed switch
6. On/Off power switch
7. Angle scale: Scale shows the tilting angle of table.
8. Adjustable light
9. Flexible shaft with drill chuck
10. Setting gauge for saw blades without pin

INSTALLATION

Setting the saw bench

Setting the angle scale

- Release the star button (1) and bring the saw bench (2) to a right angle (3) in relation to the saw blade.
- Use a 90° angle to measure the right angle between the blade and the bench. The saw blade should be 90° to the angle.
- Close the star button again when the distance between the blade and the 90° angle is at a minimum. The bench should then be at 90° to the saw blade.
- Release the lock screw and bring the indicator to the zero position. Fasten the screw. Please note: the angle scale is a useful piece of supplementary equipment, but should not be used for precision work. Use scrap wood for saw tests, adjust the bench if necessary. Note: The table should not be on the motor block, this can cause undesirable noise. Horizontal saw bench and diagonal cuts
- The saw bench can be positioned into a 45 degree diagonal position or be left in the horizontal position.
- You can read off the approximate degree of angle by using the angle scale located under the work bench. For more exact adjustment, use scrap wood for some saw tests; adjust the bench if necessary.

Blade guard assembly

Install the blade guard to the holder as shown in the diagram.

Secure the screws with a nut and washer.

- Lift the saw onto the frame and base and push it onto the workbench.
- Familiarize yourself with the saw operating elements and features.



Fig. 01

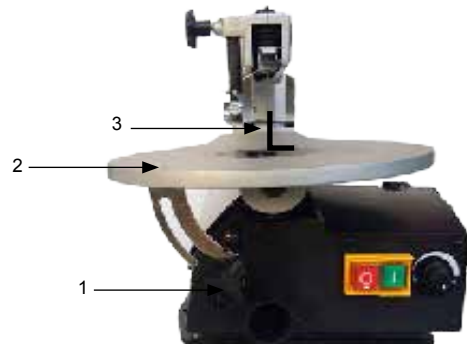

Fig. 02



Fig. 03

Mounting the saw on a work bench

- A workbench made from solid wood is better than one made of plywood, as interfering vibrations and noise are more noticeable with plywood.
- The necessary tools and small parts for assembling the saw on a workbench are not supplied with the saw. However, use equipment of at least the following size:

1. Saw body
2. Foam rubber base
3. Work bench
4. Flat seal
5. Washer
6. Hexagonal nut
7. Lock nut
8. Hexagonal bolt

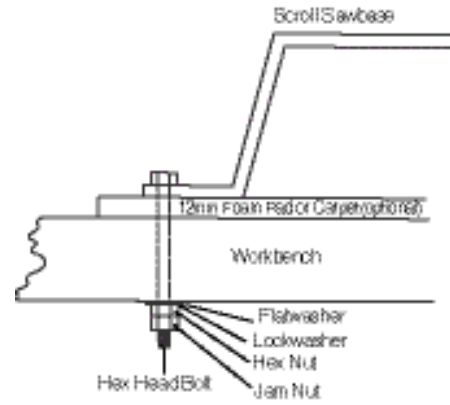

Fig. 04

Quantity Description

- 4 Hexagonal bolts (6mm) 1/4-20 x length depends on bench thickness
- 4 Flat seal (7mm) 9/32 1.0
- 4 Washers (7mm) 9/32 1.0.
- 8 Hexagonal nuts (6 mm) 1/4-20

First of all, drill holes into the seating surface and then insert the screws.

- A foam rubber base for reduction of noise is not supplied with the saw either. However, we expressly recommend that you use such a base to keep vibration and noise to a minimum. Ideal size 400 x 240 mm (15-3/4" x 9-1/2").

Changing the saw blades

Warning: Switch off the saw and remove the power cord from power supply before installing saw blades in order to avoid injuries caused by unintentional activation of the saw.

A. Flat saw blades (pinless)

Use the adapters with fl at saw-blades (1). The saw-blade is fixed with Allen screws.

A-1 Saw-blade removal

- Extract the saw-blade by sliding the table's inlay up, then unscrew the tightening screw (2).
- Slightly press the upper arm (3) down.
- Remove the saw blade by pulling it (4) forward out of the supports and through the access perforation in the table.

A-2 Inserting the saw-blade:

- Put the saw-blade with the two adapters into the lower support, the other end into the upper support.
 - Slightly press the upper arm (3) down before hooking it in.
 - Tighten the blade with the tightening screw (2) by rotating it clockwise.
- Check the tightness of the blade. Keep on rotating clockwise in order to tighten the blade even more.

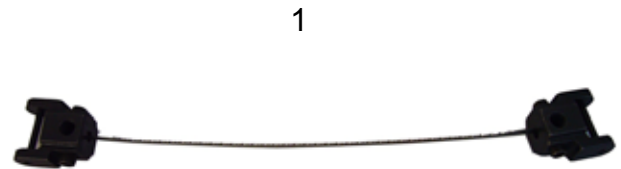

Fig. 05



Fig. 06

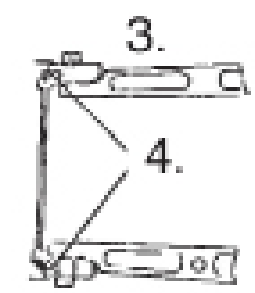

Fig. 07

B. Saw-blade with pins

B-1 Saw blade removal

- Extract the saw-blade by first unscrewing the tightening screw (2).
- Remove the saw-blade from the upper and lower support by slightly pressing the saw's upper arm down (5).

B-2 Inserting the saw-blade

- Lead one end of the saw-blade through the perforation in the table and insert the saw-blade pins into the notch.
- Repeat this procedure at the upper blade support.
- Before hooking it in, slightly press the saw's upper arm down (5)
 - Check the position of the blade pins at the supports (6).
 - Tighten the blade by means of the tightening screw (2).

Check the blade's tightness.

Keep on rotating clockwise in order to tighten the blade even more.



Fig. 08

Electrical Requirements

The installed electric motor is completely wired ready for operation.

The customer's connection to the power supply system, and any extension cables that may be used, must conform with local regulations.

Important remark:

The motor is automatically switched off in the event of an overload. The motor can be switched on again after a cooling down period that can vary with environmental temperatures.

Defective electrical connection cables

Electrical connection cables often suffer insulation damage.

Possible causes are:

- Pinch points when connection cables are run through window or door gaps.
- Kinks resulting from incorrect attachment or laying of the connection cable.
- Cuts resulting from running over the connecting cable.
- Insulation damage resulting from forcefully pulling out of the wall socket.
- Cracks through aging of insulation.

Such defective electrical connection cables must not be used as the insulation damage makes them extremely hazardous.

Check electrical connection cables regularly for damage. Make sure the cable is disconnected from the mains when checking. Electrical connection cables must comply with the regulations applicable in your country.

Single-phase motor

- The power voltage must coincide with the voltage specified on the motor's rating plate.
- Extension cables up to a length of 25m (82ft) must have a cross-section of 1.5 mm² (16ga), and beyond 25m (82ft) at least 2.5 mm² (14ga).
- The connection to the power supply must be protected with a 15 A slow-acting fuse.

Only a qualified electrician is permitted to connect the machine and complete repairs on its electrical equipment.

General Usage and Maintenance

A scroll saw is fundamentally a “curve cutting tool” but which can also carry out straight and angled edge cuts.

Familiarize yourself with the following important points prior to commissioning the saw.

- The saw does not automatically cut wood. You must feed the wood against the saw blade manually.
- The cutting process occurs while the blade is moving.
- Feed the wood slowly against the saw blade as the saw blade teeth are small.
- Persons carrying out work with the saw require training. The saw blade may break easily during this training time while the operator is still unfamiliar with the saw.
- The saw is best suited for sheets of wood less than 25 mm (1”) thick.
- Feed the wood especially slowly against the blade and avoid abrupt curves to prevent the saw blade from breaking, if you wish to cut wood sheets thicker than 25 mm (1”).
- Saw blade teeth will get dull over time, saw blades must be replaced. Blade wear depends on type of wood and operator.
- Try and make sure that the saw blade follows the grain of the wood in order to obtain a clean cut.
- The saw speed must be reduced to minimum when cutting precious and non-ferrous metals.

Inside cuts

Warning: Switch off the saw and remove the cord from power supply before installing saw blades in order to avoid injuries caused by unintentional activation of the saw. This saw is suited also to inside cuts, or cuts not starting at the edge of the work piece.

Proceed as follows:

- Drill a 6mm (1/4”) hole in the work piece.
- Turn the blade tension knob to release the tension in the blade.
- Place the bore hole over the saw blade slot in the work table.
- Install the saw blade through the hole in the work piece and through the work blade slot, and fasten the blade to the holders.
- When you have completed the inside cut, remove the saw blade and then remove the work piece from the table.

Attaching Flexible shaft

- Remove protective cap from the threaded bushing.
- Place flexible shaft onto the threaded bushing.
- Clamp tool in the drill chuck 3.2mm (1/8”) diameter.
- Firmly hold threaded shaft at the handle and switch on the speed control.
- Having finished the work, remove the flexible shaft and place the protective cap in place.

Attention: When working with the flexible shaft, cover the saw blade with the blade guard.



Fig. 09



Fig. 10



Fig. 11

Warning: In the interests of operational safety, always switch off the saw and remove the cord from power supply before carrying out maintenance work.

General

Re-application of the wax coating on the work table makes feeding the work piece to the blade easier.

Motor

The power cord should be replaced immediately if pulled out, cut or damaged in any other way.

Do not lubricate the motor bearings or internal parts!

Saw arm bearings

Lubricate the saw arm bearings every 50 hours. Proceed as follows (10).

- Turn the saw to the side
- Apply a generous amount of SAE 20 oil to the shaft end and bronze bearings.
- Let the lubricant oil work in overnight.
- Repeat the procedure the next day on the other side of the saw.

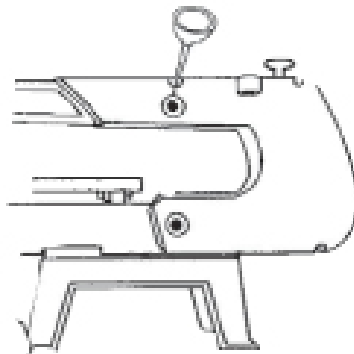

Troubleshooting

Service on these tools should only be performed by an authorized, qualified technician.

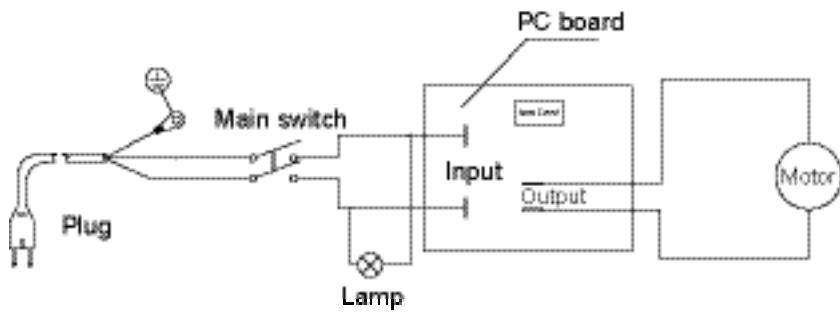

Wiring Diagram

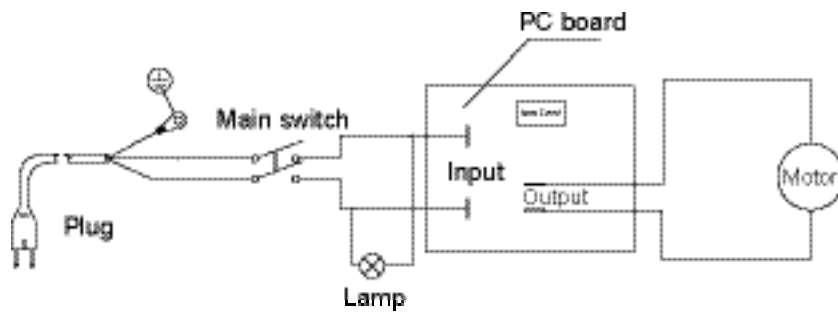

Parts List

Key number	Description		QTY	Key number	Description		QTY
1	Philips Screw	M5X8	6	49	Philips Screw	M5X6	1
2	Flat Washer	D5	6	50	Drop Foot		1
3	Side Cover		1	51	Flat Washer	D6	1
4	Hex Nut, Type I	M6	5	52	Philips Screw	M6X10	2
5	Lock Washer	D6	9	53	Cord Fix Plate		2
6	Base		1	54	Lock Washer	D8	2
7	Oil Cap		4	55	Hex Socket Screw	M8X25	2
8	Left Arm Housing		1	56	Hex Bolt	M6X20	4
9	Tension Bolt Assy		1	57	Big Flat Washer	D6	4
10	Spring		1	58	Press Spring		1
11	Pressure Plate		2	59	Hex Socket Screw	M6X35	2
12	Lock Washer	D4	3	60	Work Table Support		1
13	Hex Socket Screw	M4X10	2	61	Scale Indicator		1
14	Lower Arm		1	62	Bevel Scale		1
15	Upper Arm		1	63	Work Table		1
16	Arm Bearing		4	64	Throat plate		1
17	Philips Screw	M4X6	7	65	saw blade cover		1
18	Cord clip		5	66	Pipe		1
19	Right Arm Housing		1	67	Dust Proof Cap		1
20	Lock Washer	D5	11	68	Philips Screw	M4X8	2
21	Philips Screw	M5X35	5	69	Hex Socket Screw	M8X12	1
22	Plastic Tubing		1	70	Eccentricity Pulley		1
23	Bellows Cap		1	71	DC Motor	90W	1
24	Philips Screw	M5X28	2	72	Switch Box		1
25	Lamp Assy		1	73	strain release		1
26	Bulb	12V/10W	1	74	Philips Screw	M4X10	4
27	Lamp Fasten Nut		1	75	Variable Speed switch		1
28	Bellow		1	76	Circuit Board	120V	1
29	Fixing Plate		2	77	Table Lock Knob		1
30	Carriage Bolt	M6X20	4	78	Switch Fixing Board		1
31	Upper Blade Support		1	79	self-lock switch		1
32	Star Washer	D4	2	80	variable Speed knob		1
33	Hex Socket Screw	M4X20	2	81	Hex Socket Screw	M5X6	1
34	Bushing		2	82	Power Cord		1
35	Saw Blade		1	83	Gear shaft		1
36	Hex Socket Screw	M5X25	1	84	Bearing		2
37	Big Cushion		1	85	spring washer	D22	1
38	Eccentricity Connector Assy		1	86	spring washer	D8	4
39	Ball bearing		2	87	Big wheel		1
40	Hex Nut, Type I	M5	2	88	Key	3x8	1
41	Bracket		1	89	Shaft Connector Sleeve		1
42	Philips Screw	ST4.2X9.5	5	90	Philips Screw	M5x12	3
43	Small Cushion		1	91	Safety Screw Cap		1
44	Hex Socket Screw	M5X16	1	92	Flexible Shaft		1
45	Lower Blade Support		1	93	Belt Cover		1
46	Drop Foot Lock Knob		1	94	Pin		1
47	Drop Foot Fixing Pole		1	95	Belt		1
48	Philips Screw	M5X30	2				

Parts Explosion

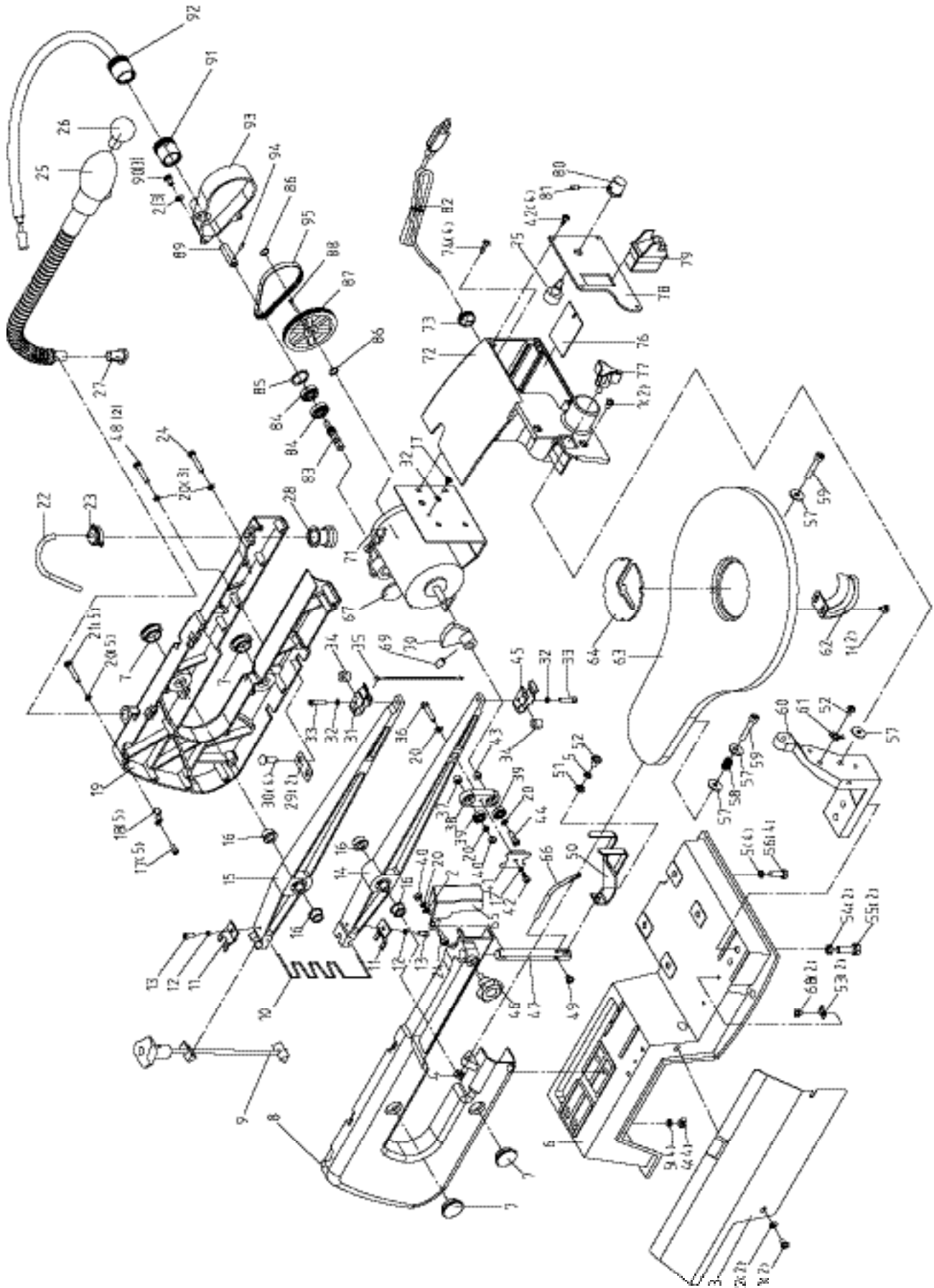



2-Year Limited Warranty

RIKON Power Tools, Inc. ("Seller") warrants to only the original retail consumer/purchaser of our products that each product be free from defects in materials and workmanship for a period of two (2) years from the date the product was purchased at retail. This warranty may not be transferred.

This warranty does not apply to defects due directly or indirectly to misuse, abuse, negligence, accidents, repairs, alterations, lack of maintenance or normal wear and tear. Under no circumstances will Seller be liable for incidental or consequential damages resulting from defective products. All other warranties, expressed or implied, whether of merchantability, fitness for purpose, or otherwise are expressly disclaimed by Seller. This warranty does not cover products used for commercial, industrial or educational purposes.

This limited warranty does not apply to accessory items such as blades, drill bits, sanding discs or belts and other related items.

Seller shall in no event be liable for death, injuries to persons or property, or for incidental, contingent, special, or consequential damages arising from the use of our products.

To take advantage of this warranty proof of purchase documentation, which includes date of purchase and an explanation of the complaint, must be provided.

The Seller reserves the right to effect at any time, without prior notice, those alterations to parts, fittings, and accessory equipment which they may deem necessary for any reason whatsoever.

To take advantage of this warranty, please fill out the enclosed warranty card and send it to:
RIKON Warranty
16 Progress Road
Billerica, MA 01821

The card must be entirely completed in order for it to be valid. If you have any questions please contact us at 877-884-5167 or warranty@rikontools.com.



**For more information:
16 Progress Road
Billerica, MA 01821**

**877-884-5167 / 978-528-5380
techsupport@rikontools.com
www.rikontools.com**

