

## 18" Bandsaw

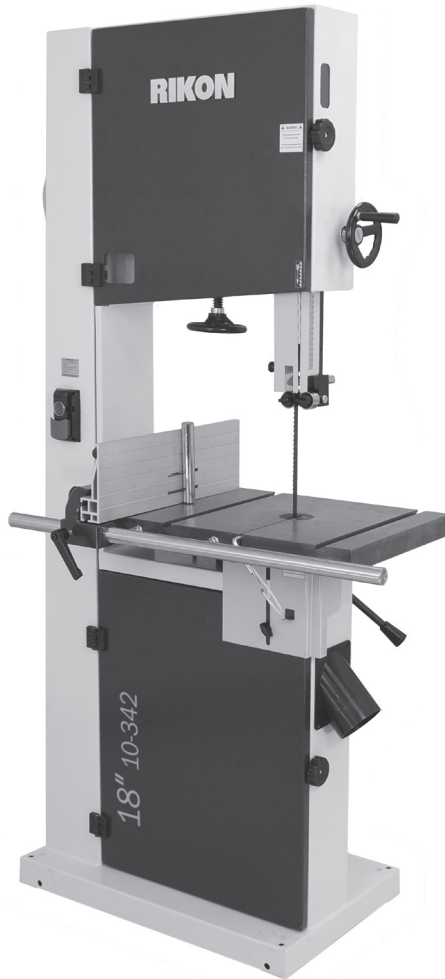

# Operator's Manual

Record the serial number and date of purchase in your manual for future reference.

Serial Number: \_\_\_\_\_ Date of purchase: \_\_\_\_\_

For technical support or parts questions, email [techsupport@rikontools.com](mailto:techsupport@rikontools.com) or call toll free at (877)884-5167

## TABLE OF CONTENTS

Specifications.....	2
Safety Instructions .....	3 - 6
Getting To Know Your Machine .....	7
Contents of Package .....	8 - 9
Installation .....	9
Assembly .....	10 - 12
Adjustments.....	12 - 20
Operation .....	21,22
Maintenance .....	22,23
Wiring Diagram .....	22
Notes .....	23
Troubleshooting .....	24 - 27
Parts Diagrams & Parts Lists .....	28 - 37
Accessories .....	38
Warranty .....	39

## SPECIFICATIONS

Motor .....	2 HP, TEFC
Motor Speed (no load).....	1,720 RPM
Volts .....	220 V
Amps, Hertz .....	7.5 A, 60 Hz
Blade Length .....	153" (3,886 mm)
Blade Width .....	1/4" - 1-3/8" (6.35 - 35 mm)
Blade Speed .....	3,280 ft/min (1,000 m/min)
Table Size (W x D) .....	21-1/2" x 15-3/4" (546 x 400 mm)
Table Side Extension Size (W x D).....	4-3/8" x 15-3/4" (110 x 400 mm)
Table Tilt .....	Left -10°, Right 45°
Maximum Cutting Width (throat) .....	17-1/2" (445 mm)
Maximum Cutting Depth (height) .....	13" (330 mm)
Table Height .....	35-1/2" (902 mm)
Fence Height .....	6" (152 mm)
Fence Length .....	18-3/4" (475 mm)
Miter Gauge T-Slots (2) .....	3/4" x 3/8" (19.05 x 9.5 mm)
Dust Ports (2) .....	4" Diameter (100 mm)
Base Size .....	29-11/32" x 18-1/8" x 2-7/16" (745 x 460 x 62.5 mm)
Overall Height .....	72-7/8" (1850 mm)
Overall Size (WxDxH) .....	38-1/2"x29-1/8"x72-7/8" (976x740x1850 mm)
Net Weight .....	328 lbs (149 kg)

**NOTE:** The specifications, photographs, drawings and information in this manual represent the current model when the manual was prepared. Changes and improvements may be made at any time, with no obligation on the part of Rikon Power Tools, Inc. to modify previously delivered units. Reasonable care has been taken to ensure that the information in this manual is correct, to provide you with the guidelines for the proper safety, assembly and operation of this machine.

# SAFETY INSTRUCTIONS

**IMPORTANT!** Safety is the single most important consideration in the operation of this equipment. **The following instructions must be followed at all times.** Failure to follow all instructions listed below may result in electric shock, fire, and/or serious personal injury.

There are certain applications for which this tool was designed. We strongly recommend that this tool not be modified and/or used for any other application other than that for which it was designed. If you have any questions about its application, do not use the tool until you have contacted us and we have advised you.

---

## SAFETY SYMBOLS



**SAFETY ALERT SYMBOL:** Indicates DANGER, WARNING, or CAUTION. This symbol may be used in conjunction with other symbols or pictographs.



Indicates an imminently hazardous situation, which, if not avoided, could result in death or serious injury.



Indicates a potentially hazardous situation, which, if not avoided, could result in death or serious injury.



Indicates a potentially hazardous situation, which, if not avoided, could result in minor or moderate injury.

**NOTICE:** Shown without Safety Alert Symbol indicates a situation that may result in property damage.

---

## GENERAL SAFETY

**KNOW YOUR POWER TOOL.** Read the owner's manual carefully. Learn the tool's applications, work capabilities, and its specific potential hazards.

### BEFORE USING YOUR MACHINE

To avoid serious injury and damage to the tool, read and follow all of the Safety and Operating Instructions before operating the machine.

1. Some dust created by using power tools contains chemicals known to the State of California to cause cancer, birth defects, or other reproductive harm.

Some examples of these chemicals are:

- Lead from lead-based paints.
- Crystalline silica from bricks, cement, and other masonry products.
- Arsenic and chromium from chemically treated lumber.

Your risk from these exposures varies, depending on how often you do this type of work. To reduce your exposure to these chemicals: work in a well ventilated area and work with approved safety equipment, such as those dust masks that are specially designed to filter out microscopic particles.

2. **READ** the entire Owner's Manual. **LEARN** how to use the tool for its intended applications.

3. **GROUND ALL TOOLS.** If the tool is supplied with a 3 prong plug, it must be plugged into a 3-contact electrical receptacle. The 3rd prong is used to ground the tool and provide protection against accidental electric shock. **DO NOT** remove the 3rd prong. See Grounding Instructions on the following pages.

4. **AVOID A DANGEROUS WORKING ENVIRONMENT.** **DO NOT** use electrical tools in a damp environment or expose them to rain.

5. **DO NOT** use electrical tools in the presence of flammable liquids or gasses.

6. **ALWAYS** keep the work area clean, well lit, and organized. **DO NOT** work in an environment with floor surfaces that are slippery from debris, grease, and wax.

7. **KEEP VISITORS AND CHILDREN AWAY. DO NOT** permit people to be in the immediate work area, especially when the electrical tool is operating.

8. **DO NOT FORCE THE TOOL** to perform an operation for which it was not designed. It will do a safer and higher quality job by only performing operations for which the tool was intended.

9. **WEAR PROPER CLOTHING. DO NOT** wear loose clothing, gloves, neckties, or jewelry. These items can get caught in the machine during operations and pull the operator into the moving parts. The user must wear a protective cover on their hair, if the hair is long, to prevent it from contacting any moving parts.

10. **CHILDPROOF THE WORKSHOP AREA** by removing switch keys, unplugging tools from the electrical receptacles, and using padlocks.

11. **ALWAYS UNPLUG THE TOOL FROM THE ELECTRICAL RECEPTACLE** when making adjustments, changing parts or performing any maintenance.

# SAFETY INSTRUCTIONS

## 12. KEEP PROTECTIVE GUARDS IN PLACE AND IN WORKING ORDER.

13. **AVOID ACCIDENTAL STARTING.** Make sure that the power switch is in the “OFF” position before plugging in the power cord to the electrical receptacle.

14. **REMOVE ALL MAINTENANCE TOOLS** from the immediate area prior to turning “ON” the machine.

15. **USE ONLY RECOMMENDED ACCESSORIES.** Use of incorrect or improper accessories could cause serious injury to the operator and cause damage to the tool. If in doubt, check the instruction manual that comes with that particular accessory.

16. **NEVER LEAVE A RUNNING TOOL UNATTENDED.** Turn the power switch to the “OFF” position. **DO NOT** leave the tool until it has come to a complete stop.

17. **DO NOT STAND ON A TOOL.** Serious injury could result if the tool tips over, or you accidentally contact the tool.

18. **DO NOT** store anything above or near the tool where anyone might try to stand on the tool to reach it.

19. **MAINTAIN YOUR BALANCE. DO NOT** extend yourself over the tool. Wear oil resistant rubber soled shoes. Keep floor clear of debris, grease, and wax.

20. **MAINTAIN TOOLS WITH CARE.** Always keep tools clean and in good working order. Keep all blades and tool bits sharp, dress grinding wheels and change other abrasive accessories when worn.

21. **EACH AND EVERY TIME, CHECK FOR DAMAGED PARTS PRIOR TO USING THE TOOL.** Carefully check all guards to see that they operate properly, are not damaged, and perform their intended functions. Check for alignment, binding or breaking of moving parts. A guard or other part that is damaged should be immediately repaired or replaced.

22. **DO NOT OPERATE TOOL WHILE TIRED, OR UNDER THE INFLUENCE OF DRUGS, MEDICATION OR ALCOHOL.**

23. **SECURE ALL WORK.** Use clamps or jigs to secure the workpiece. This is safer than attempting to hold the workpiece with your hands.

24. **STAY ALERT, WATCH WHAT YOU ARE DOING, AND USE COMMON SENSE WHEN OPERATING A POWER TOOL.**

A moment of inattention while operating power tools may result in serious personal injury.

25. **ALWAYS WEAR A DUST MASK TO PREVENT INHALING DANGEROUS DUST OR AIRBORNE PARTICLES,** including wood dust, crystalline silica dust and asbestos dust. Direct particles away from face and body. Always operate tool in well ventilated area and provide for proper dust removal. Use dust collection system wherever possible. Exposure to the dust may cause serious and permanent respiratory or other injury, including silicosis (a serious lung disease), cancer, and death. Avoid breathing the dust, and avoid prolonged contact with dust. Allowing dust to get into your mouth or eyes, or lay on your skin may promote absorption of harmful material. Always use properly fitting NIOSH/OSHA approved respiratory protection appropriate for the dust exposure, and wash exposed areas with soap and water.

26. **USE A PROPER EXTENSION CORD IN GOOD CONDITION.** When using an extension cord, be sure to use one heavy enough to carry the current your product will draw. The table on the following page shows the correct size to use depending on cord length and nameplate amperage rating. If in doubt, use the next heavier gauge. The smaller the gauge number, the larger diameter of the extension cord. If in doubt of the proper size of an extension cord, use a shorter and thicker cord. An undersized cord will cause a drop in line voltage resulting in a loss of power and overheating.  
**USE ONLY A 3-WIRE EXTENSION CORD THAT HAS A 3-PRONG GROUNDING PLUG AND A 3-POLE RECEPTACLE THAT ACCEPTS THE TOOL’S PLUG.**

27. **ADDITIONAL INFORMATION** regarding the safe and proper operation of this product is available from:

- Power Tool Institute  
1300 Summer Avenue  
Cleveland, OH 44115-2851  
[www.powertoolinstitute.org](http://www.powertoolinstitute.org)
- National Safety Council  
1121 Spring Lake Drive  
Itasca, IL 60143-3201  
[www.nsc.org](http://www.nsc.org)
- American National Standards Institute  
25 West 43rd Street, 4th Floor  
New York, NY 10036  
[www.ansi.org](http://www.ansi.org)
- ANSI 01.1 Safety Requirements for Woodworking Machines and the U.S. Department of Labor regulations  
[www.osha.gov](http://www.osha.gov)

28. **SAVE THESE INSTRUCTIONS.** Refer to them frequently and use them to instruct others.

# SAFETY INSTRUCTIONS

## ELECTRICAL SAFETY

**⚠ WARNING:** THIS TOOL REQUIRES THE INSTALLATION OF A 220V PLUG (NOT INCLUDED), AND MUST BE GROUNDED WHILE IN USE TO PROTECT THE OPERATOR FROM ELECTRIC SHOCK.

IN THE EVENT OF A MALFUNCTION OR BREAKDOWN, grounding provides the path of least resistance for electric current and reduces the risk of electric shock. This tool is equipped with an electric cord that has an equipment grounding conductor and requires a grounding plug (not included). The plug **MUST** be plugged into a matching electrical receptacle that is properly installed and grounded in accordance with **ALL** local codes and ordinances.

**DO NOT MODIFY ANY PLUG.** If it will not fit the electrical receptacle, have the proper electrical receptacle installed by a qualified electrician.

**IMPROPER ELECTRICAL CONNECTION** of the equipment grounding conductor can result in risk of electric shock. The conductor with the green insulation (with or without yellow stripes) is the equipment grounding conductor. **DO NOT** connect the equipment grounding conductor to a live terminal if repair or replacement of the electric cord or plug is necessary.

**CHECK** with a qualified electrician or service personnel if you do not completely understand the grounding instructions, or if you are not sure the tool is properly grounded when installing or replacing a plug.

### REPLACE A DAMAGED OR WORN CORD IMMEDIATELY.

This tool is intended for use on a circuit that has a 220 volt electrical receptacle. **FIGURE 1** shows the type of the 220V, 4-wire electrical plug and electrical receptacle that has a grounding conductor that is required.

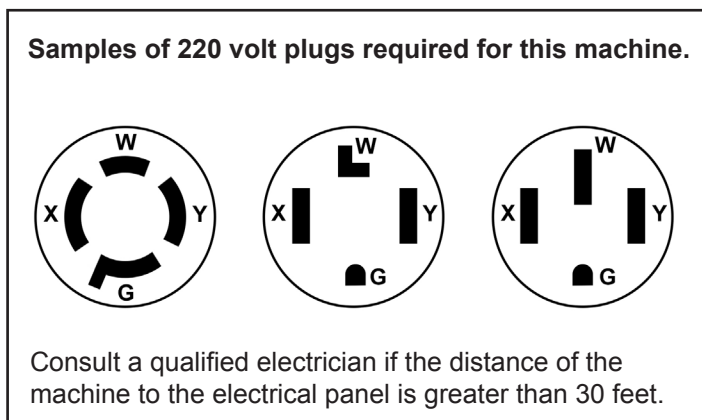

Figure 1

## EXTENSION CORDS

**⚠ WARNING:** USE OF AN EXTENSION CORD WITH THIS MACHINE IS NOT RECOMMENDED. FOR BEST POWER AND SAFETY, PLUG THE MACHINE DIRECTLY INTO A DEDICATED GROUNDED ELECTRICAL OUTLET THAT IS WITHIN THE SUPPLIED CORD LENGTH OF THE MACHINE.

IF AN EXTENSION CORD NEEDS TO BE USED, IT SHOULD ONLY BE FOR LIMITED OPERATION OF THE MACHINE. THE EXTENSION CORD SHOULD BE AS SHORT AS POSSIBLE IN LENGTH, AND HAVE A MINIMUM GAUGE SIZE OF 14AWG.

USE ONLY A 4-WIRE EXTENSION CORD THAT HAS THE PROPER TYPE OF A 4-PRONG GROUNDING PLUG THAT MATCHES THE MACHINE'S 4-PRONG PLUG AND ALSO THE 4-POLE RECEPTACLE THAT ACCEPTS THE TOOL'S PLUG. \*

**⚠ WARNING:** Check extension cords before each use. If damaged replace immediately. Never use a tool with a damaged cord, since touching the damaged area could cause electrical shock, resulting in serious injury.

Use a proper extension cord. Only use cords listed by Underwriters Laboratories (UL). Other extension cords can cause a drop in line voltage, resulting in a loss of power and overheating of tool. When operating a power tool outdoors, use an outdoor extension cord marked "W-A" or "W". These cords are rated for outdoor use and reduce the risk of electric shock.

**⚠ WARNING:** Keep the extension cord clear of the working area. Position the cord so that it will not get caught on lumber, tools or other obstructions while you are working with a power tool.

\* Canadian electrical codes require extension cords to be certified SJT type or better.

\*\* The use of an adapter in Canada is not acceptable.



THIS SYMBOL DESIGNATES THAT THIS TOOL IS LISTED BY THE INTERTEK TESTING SERVICES, TO UNITED STATES AND CANADIAN STANDARDS.

# SAFETY INSTRUCTIONS

## SPECIFIC SAFETY INSTRUCTIONS FOR BAND SAWS

This machine is intended for the cutting of natural, solid woods, composite materials, plastics and non-ferrus metals. The permissible workpiece dimensions must be observed (see Technical Specification). Any other use not as specified, including modification of the machine or use of parts not tested and approved by the equipment manufacturer, can cause unforeseen damage and invalidate the warranty.

**ATTENTION:** Use of this band saw still presents risks that cannot be eliminated by the manufacturer. Therefore, the user must be aware that wood working machines are dangerous if not used with care and all safety precautions are adhered to.

1. Do not operate this machine until you have read all of the following instructions.
2. If you are not familiar with the operation of the machine, obtain assistance from a qualified person.
3. Always wear approved, safety protective eye wear and hearing protection when operating this machine.
4. Always wear a dust mask and use adequate dust collection and proper ventilation.
5. Adjust the upper guides about 1/8" to 1/4" above the material being cut.
6. Check for proper blade size and type for the thickness and type of material being cut.
7. Make sure that the blade tension and blade tracking are properly adjusted.
8. Always keep hands and fingers away from the blade.
9. Make "relief" cuts before cutting curves to eliminate blade binding.
10. Always hold material firmly, resting flat on the table and feed it into the blade at a moderate speed.
11. Never attempt to saw stock that does not have a flat surface, unless a suitable support is used.
12. When cutting small work pieces, always use a push stick, holding jig or other device to keep your hands safely away from the blade. Use 'Zero Clearance Inserts' to prevent small pieces from becoming jammed in the table insert or lower blade guides.
13. Always allow the bandsaw blade to stop before removing scrap pieces from the table.
14. Do not remove jammed pieces from the saw until the machine and blade has stopped. Unplug the bandsaw from the power source, and then remove the jammed work piece.
15. Always turn off the machine if the material is to be backed out of an uncompleted cut.
16. Use extra supports (roller stands, saw horses, tables etc.) for any work pieces large enough to tip when not held down to the table top surface.
17. Always turn off and unplug the machine when changing blades or servicing the machine.
18. Release blade tension when the saw will not be used for a long period of time.
19. Remove material or debris from the work area. Keep work area neat and clean.

## SAVE THESE INSTRUCTIONS.

Refer to them often.

### California Proposition 65 Warning

**WARNING:** Some dust created by power sanding, sawing, grinding, drilling, and other construction activities contains chemicals known to the State of California to cause cancer and birth defects or other reproductive harm. Your risk from exposure to these chemicals varies, depending on how often you do this type of work. To reduce your exposure, work in a well-ventilated area and with approved safety equipment, such as dust masks that are specially designed to filter out microscopic particles.

For more detailed information about California Proposition 65 log onto [www.rikontools.com](http://www.rikontools.com).

**This owner's manual is not a teaching aid. Use of this owner's manual is intended to show assembly, adjustments, and general use.**

## GETTING TO KNOW YOUR MACHINE

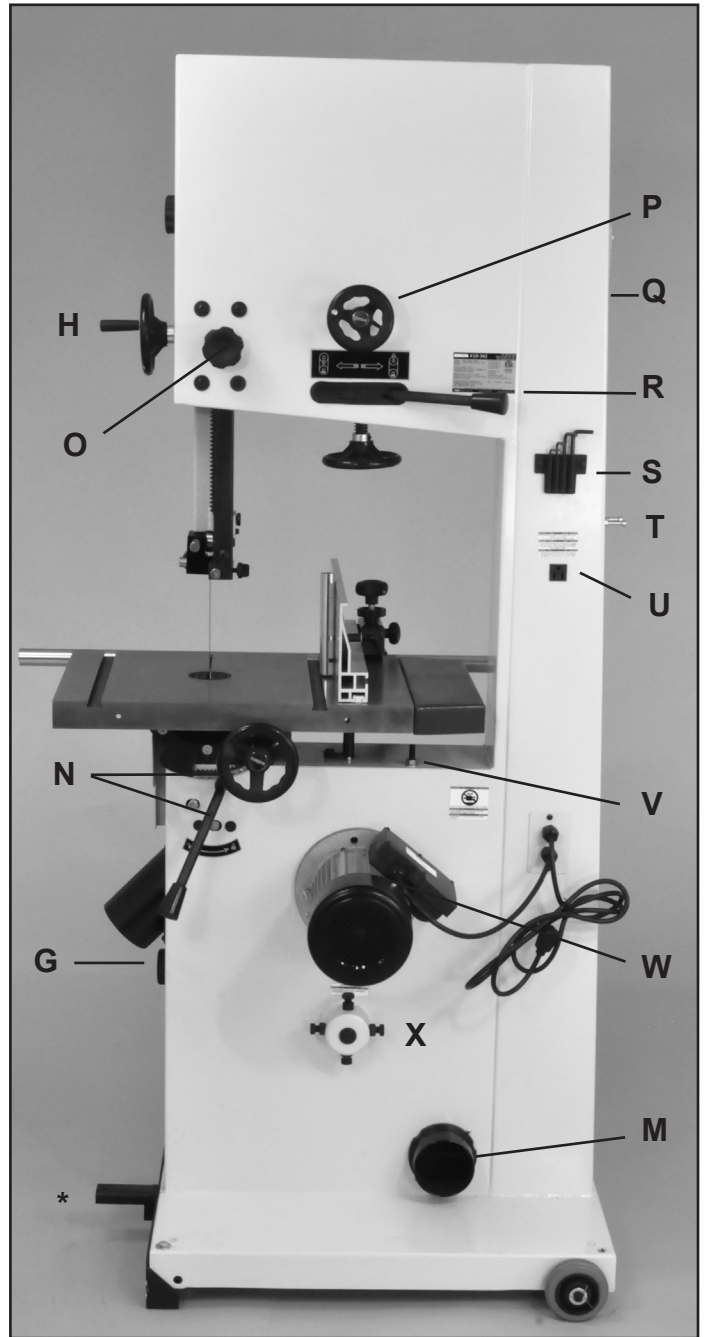
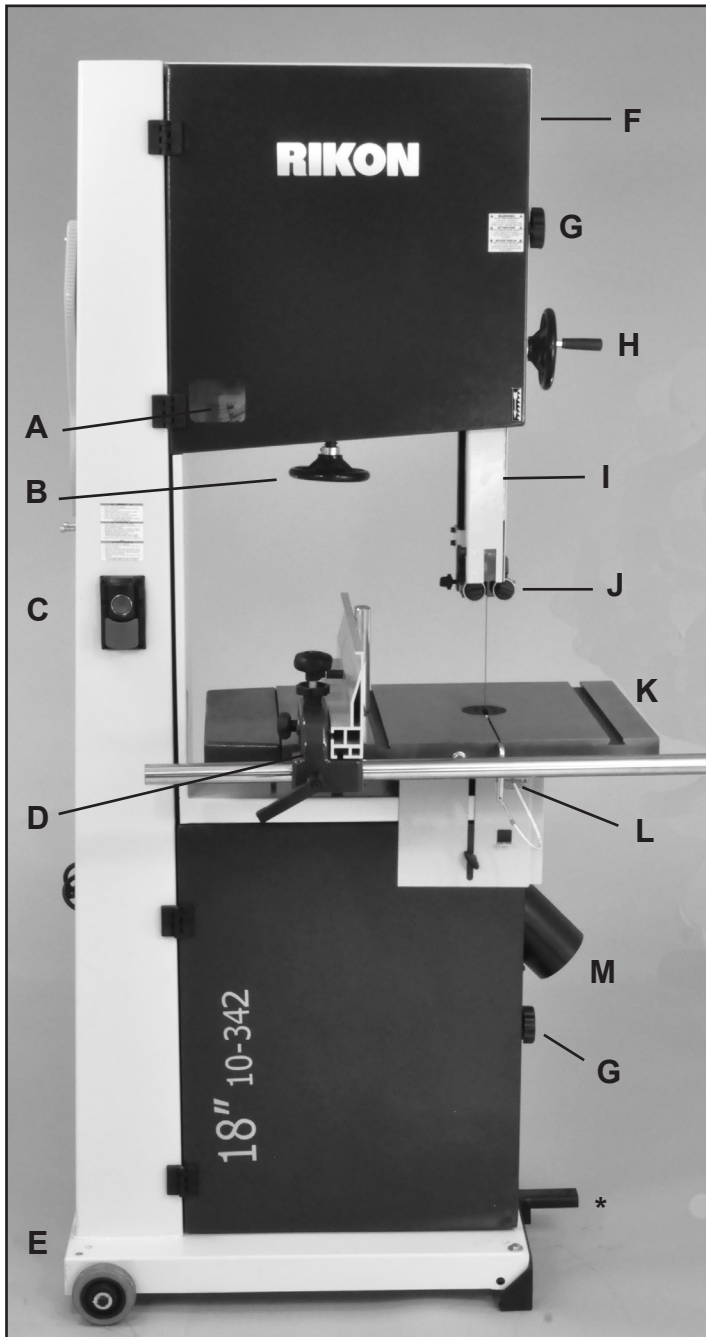

\* 10-342 BANDSAW SHOWN WITH OPTIONAL MOBILITY KIT BASE ATTACHED (13-345). OPTIONAL KIT'S TOW BAR ALSO NOT SHOWN.

- A. Tension Indicator Window
- B. Blade Tension Hand Wheel
- C. On/Off Switch
- D. Rip Fence, Rail & Re-saw Bar
- E. Base
- F. Blade Tracking Window
- G. Door Lock Knob
- H. Guide Post Rise/Fall Handle
- I. Blade Guard
- J. Upper Blade Guides
- K. Work Table
- L. Lower Blade Guides & Blade Guard

- M. 4" Dust Port
- N. Table Tilt Wheel & Locking Handle
- O. Guide Post Lock Knob
- P. Blade Tracking Knob
- Q. Push Stick & Hanger Bolt
- R. Blade Tension Quick Release Lever
- S. Tool Holder
- T. Hanger Bolts for Tow Bar (optional)
- U. Electrical Outlet 110V
- V. Motor Adjusting Rod & Nut
- W. Motor & Wiring Box
- X. Lower Wheel Adjustment Bolts

# CONTENTS OF PACKAGE

Model 10-342 18" Bandsaw is shipped complete in one box.

## Unpacking, Checking Contents & Clean-up

1. Carefully remove all contents from the shipping carton. Compare the contents with the list of contents to make sure that all of the items are accounted for, before discarding any packing material. Place parts on a protected surface for easy identification and assembly. If any parts are missing or broken, please call RIKON Customer Service (877- 884-5167) as soon as possible for replacements. DO NOT turn your machine ON if any of these items are missing. You may cause injury to yourself or damage to the machine.
2. Report any shipping damage to your local distributor.
3. With the help of another person, carefully lift the Bandsaw from the packaging and place it on a level floor.
4. Clean all rust protected surfaces with ordinary house hold type grease or spot remover. Do not use; gasoline, paint thinner, mineral spirits, etc. These may damage painted surfaces.
5. Apply a coat of paste wax to the table to prevent rust. Wipe all parts thoroughly with a clean dry cloth. Be careful, as the pre-installed bandsaw blade has sharp teeth and may cause injury if touched.
6. Set packing material and shipping carton aside. Do not discard until the machine has been set up and is running properly.

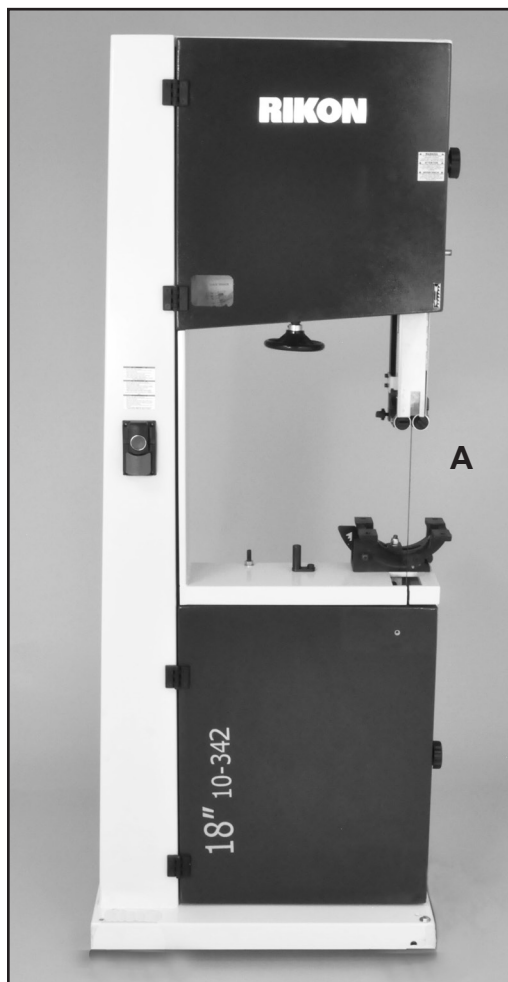

## TABLE OF LOOSE PARTS

- A. Bandsaw Frame Assembly
- B. Table with Extension and Blade Insert
- C. Rip Fence Front Rail and Hardware
- D. Leveling Pin and Lanyard
- E. Table Leveling Bolt and Nut
- F. Table Mounting Bolts and Washers
- G. Manual and Warranty Card - not shown

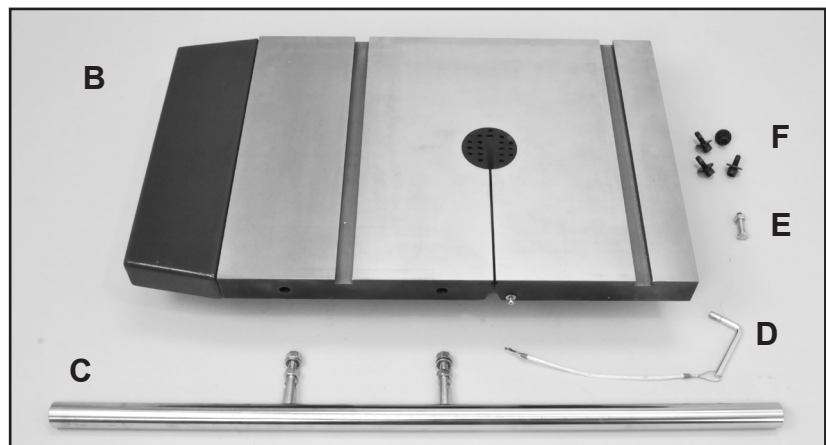

Link to RIKON website,  
10-342 Product Page and  
ASSEMBLY VIDEO





# CONTENTS OF PACKAGE

## TABLE OF LOOSE PARTS continued

### Rip Fence Assembly & Parts:

- A. Rip Fence
- B. Rip Fence Carrier Assembly
- C. Push Stick and Mounting Bolt and Nut
- D. Hanger Bolts for Tow Bar (accessory item)
- E. Re-saw Bar Assembly

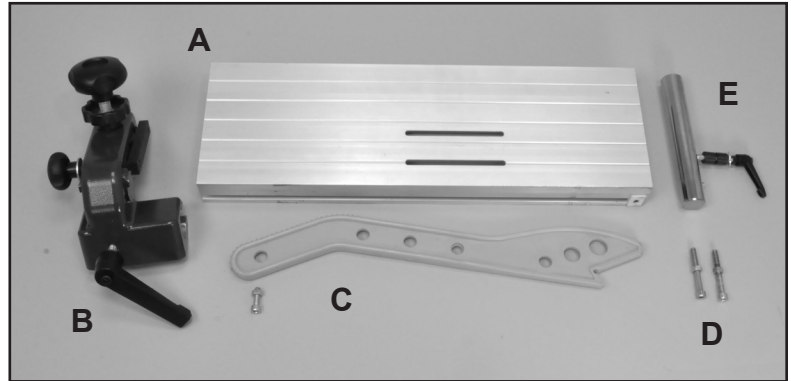

### Parts for Assembly on Frame:

- F. Dust Port & Mounting Screws
- G. Handwheels (2)
- H. Handles for Handwheels (2)
- I. Lower Blade Guard and Knob

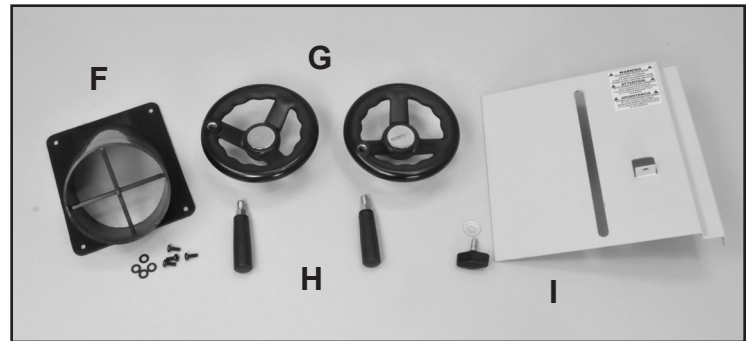

### Tools and Tool Holder:

- J. Wrenches: 10, 13 mm
- K. Hex Wrenches; 3, 4, 5, 6 mm
- L. Tool Holder and Mounting Screws

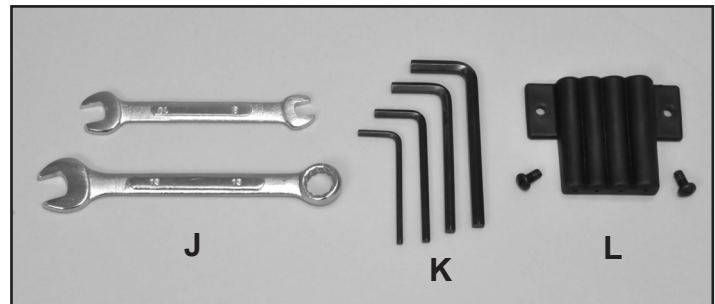

### Additional Tools required - not supplied

- #2 Phillips Screwdriver
- 16mm or an Adjustable Wrench

# INSTALLATION

## MOVING & INSTALLING THE BANDSAW

**CAUTION** The bandsaw is heavy - over 300 lbs! It is best to assemble the machine near the area where it will eventually reside. When moving or positioning an assembled bandsaw, DO NOT use the table or upper blade guard assemblies as this may damage the machine. Move the bandsaw by grasping the support column and lower frame which are all welded together for rigidity. The bandsaw can also be moved by laying it down on the back/left side of the column so that the table assembly is not compromised.

1. Carefully remove the machine from the shipping carton. See above instructions on handling the saw.

2. Position the machine on a solid, level foundation that is located in an area that has ample space in front, right side and in back of the bandsaw for cutting large or long material.

For best power and safety, the bandsaw should be plugged directly into a dedicated grounded electrical outlet that is within the supplied cord length of the machine. The use of an extension cord is not recommended.

3. Align the machine so that during use, the material being cut will not face aisles, doorways, or other work areas that bystanders may be in. Do not locate or use the machine in damp or wet conditions.

4. Once in place in your shop, level the machine with spacers, and secure it to the floor with lag screws (not supplied) using the 4 holes in the saw's base.

# ASSEMBLY

**WARNING** THE MACHINE MUST NOT BE PLUGGED IN AND THE POWER SWITCH MUST BE IN THE OFF POSITION UNTIL ASSEMBLY IS COMPLETE.

**NOTE:** Parts referenced throughout the manual refer to the different sheets and key numbers of the Parts Diagrams and Parts Lists on pages 28 to 37. Example: (#1A) refers to Part #1 on Sheet A.



FIGURE 1

## TABLE ASSEMBLY

1. Mount the table (Fig. 1) in place on the trunnion with the assistance of another person. The table is heavy! Do this from the rear of the machine, so that it is easier to fit the pre-installed blade through the slot in the table.

2. Attach the table to the trunnion with the four Hex Socket Cap Screws, Spring Washers and Washers (Parts #13B, 12B, 11B). Install two bolts to the right of the blade, hand tightened only. Fig. 2. Then tip the table to 45 degrees and install the two bolts to the left of the blade. Fig. 3. DO NOT fully tighten the bolts at this time. Return the table to the horizontal position.

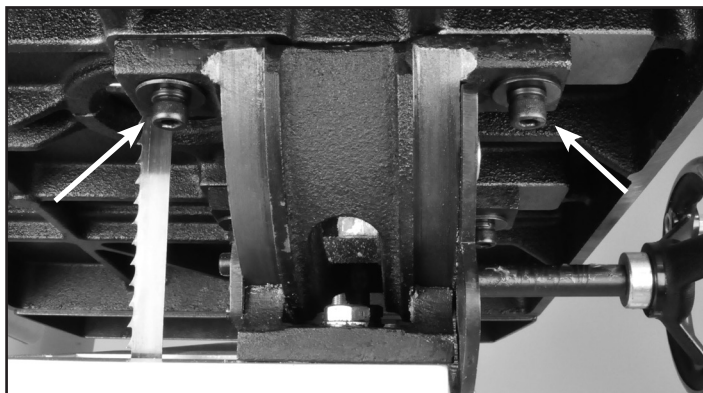

FIGURE 2

**NOTE:** Before finally secured in position, the table can be slightly moved, left and right. Check to make sure that the table's miter gauge slot is parallel to the side of the saw blade. This will provide a true cut when ripping stock. Set a thin metal ruler against the side of the saw blade. Make sure that it is not touching the saw's teeth, which can angle the ruler. Measure the distance from one end of the ruler to the miter gauge slot. FIG. 4. Then measure the same distance from the other end of the ruler to the miter gauge slot. Compare these two measurements and angle the table as necessary until the distances are the same.

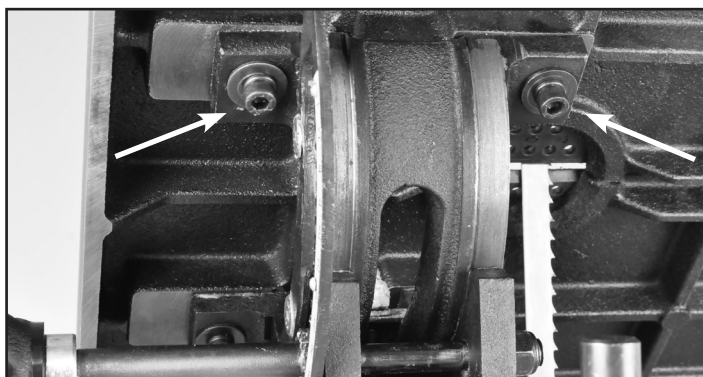

FIGURE 3

3. Once the table is aligned parallel to blade, tighten all four of the installed bolts to secure the table in place.

4. Attach the Table Leveling Pin's Lanyard (Part #5B) to the front of the table with the supplied Phillips Screw and Washer. This metal pin keeps the two sides of the table level at the slot area.

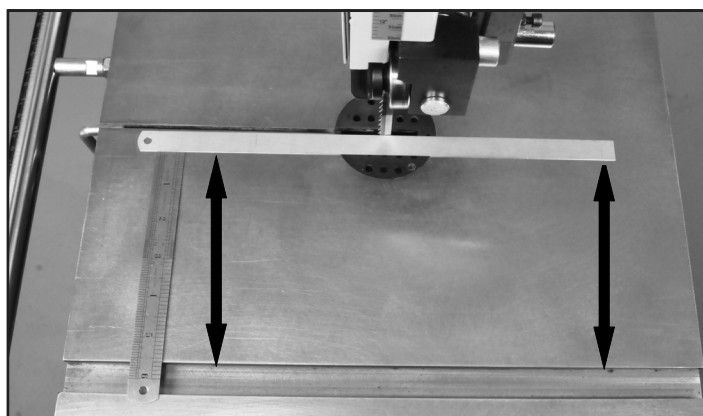
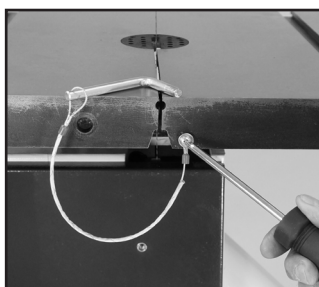

FIGURE 4

# ASSEMBLY

## RIP FENCE ASSEMBLY

1. Mount the fence Guide Rail (#12E) onto the front table edge with the two fence bar Nuts and Washers (#14E, 5E) Fig. 5. Position the bar so that it is parallel with the table surface, and equal distance out from the front edge of the table when measured at both left and right front edges of the table.
2. Slide the Fence Carrier Assembly (#9E) onto the fence's guide rail. Fig. 6.
3. Slide the Rip Fence (#18E) onto the fence carrier, and lock it in place by tightening the fence lock Knob (#7E) which is located on the carrier, opposite side to the fence. Fig. 6, A.
4. With the front Locking Handle (#10E, Fig. 6,B) secure the fence on the rail so that it does not move during the rest of the assembly process. Final adjustments to the fence are covered on pages 18 to 20. Information on the re-saw bar is on page 21.



FIGURE 5

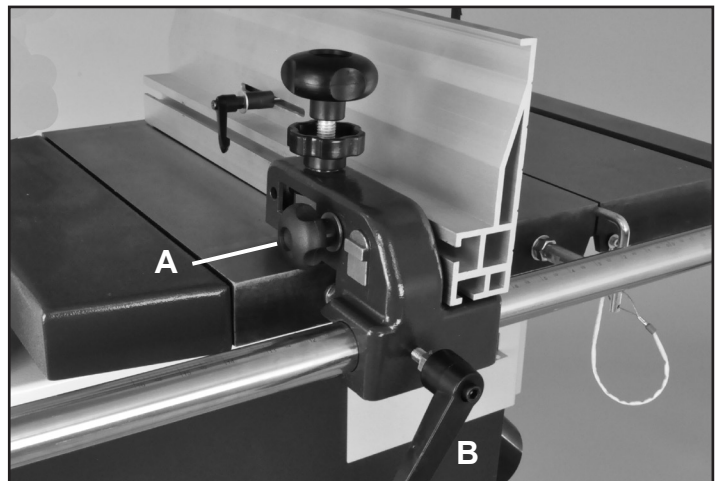
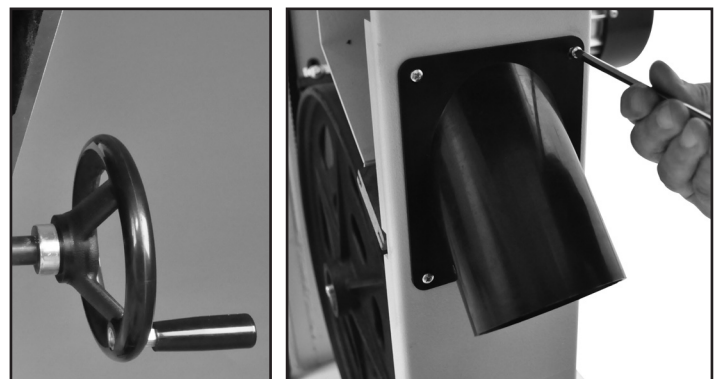

FIGURE 6

## INSTALL THE HAND WHEELS

1. Attach the small Handle (#25B) to the large Handwheel (#24B) that tilts the table. Then install this handwheel onto the Gear Shaft (#23B) extending out from the trunnion at the back of the machine. Fig. 7A.
2. Attach the second small Handle to the Handwheel (#38C) that has been pre-installed at the upper right side of the saw frame. This wheel raises and lowers the blade guard.



A

FIGURE 7

B

## INSTALL THE 4" DUST PORT

Mount the 4" Dust Port (#53A) under the table on the right side of the saw frame with four pan head screws and flat washers (#51A, 52A) using a Phillips screw driver. Fig. 7B.

## INSTALL THE LOWER BLADE GUARD

Attach the Blade Guard (#19A) to the front of the lower door with the Handle and Washer (#17A, 18A). Slide the guard up to protect the lower guides during use, and slide the guard down when adjusting the lower guides is needed. Fig. 8A.

## INSTALL THE 90° TABLE STOP

1. Tilt the table to gain access to its underside.
2. Thread the Hex Screw (#9B) and Nut (#8B) to the bottom of the table in the pre-bored and tapped hole. Fig. 8B. Setting the table to 90° to the blade will be done later on pages 12 and 13.

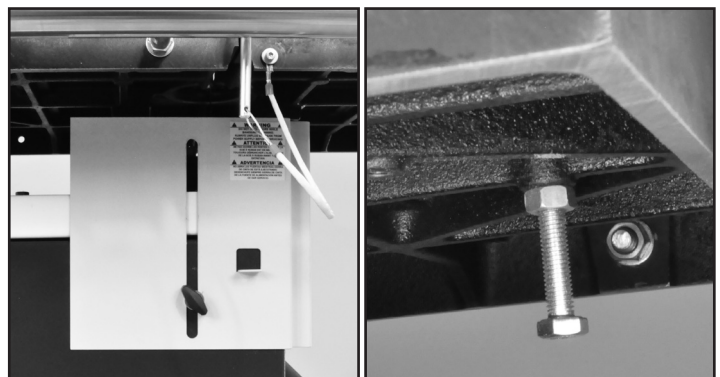

A

FIGURE 8

B

# ASSEMBLY

## INSTALL THE TOOL HOLDER

Assemble the Tool Holder (#68A) to the column rear with two Phillips Screws. Fig. 9, A.

Handy storage for the Hex Wrenches (3, 4, 5, 6mm).

## INSTALL THE PUSH STICK HOLDER

Assemble the Push Stick Hanger Bolt (#4A) to the column's left side with a 5mm hex wrench. Handy storage for the push stick when not in use. FIG. 9, B.

## INSTALL THE TOW BAR HOLDER

Two bolts (#4A) are included to store the tow bar included with the optional Mobility Kit #13-345. Screw the bolts into the column's left side. Fig. 10, C.



FIGURE 9

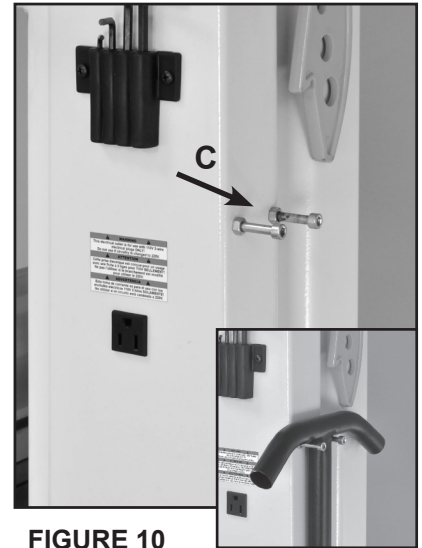

FIGURE 10

# ADJUSTMENTS



**WARNING** THE MACHINE MUST NOT BE PLUGGED IN AND THE POWER SWITCH MUST BE IN THE OFF POSITION UNTIL ALL ADJUSTMENTS ARE COMPLETE.

## TILTING THE TABLE

1. At the rear of the saw, loosen the Quick Locking Handle (#74A) on the table trunnion by pulling it upward. Fig.11, A.
2. Turn the table tilting Handwheel (#24B) to adjust the table to the desired angle. Fig. 11, B. Use the angle indicator scale (#32B) on the trunnion bracket (#27B) to find the desired angle, Fig. 11, C.
3. Retighten the lock handle to secure the table.

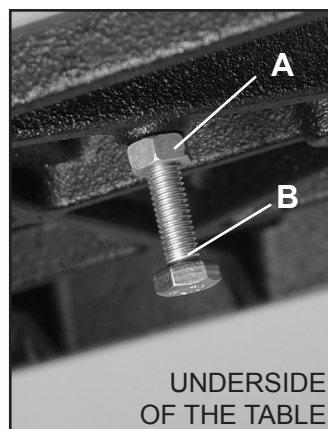

FIGURE 11

## SETTING THE TABLE SQUARE TO THE SAW BLADE'S SIDE

The table may be set at 90° to the saw blade sides by adjusting the table stop Bolt (#9B) under the table. The table stop bolt rests on the top of the pivoting Stop Block (#62A).

1. First loosen the bolt's Locking Nut (#8B) Fig. 12, A.
2. Set a square on the table and against the saw blade's flat side. Tilt the table until the table is set exactly 90° to the blade, then lock the table in position.
3. Adjust the bolt (Fig. 12, B), up or down, until it is in contact with the pivoting Table Angle Stop Block (#62A) Fig. 12, C. Retighten the locking nut making sure that the table angle setting is maintained.



UNDERSIDE OF THE TABLE

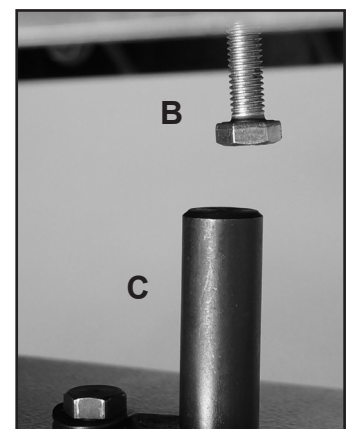

FIGURE 12

CONTINUED ON PAGE 13

# ADJUSTMENTS

## SETTING THE TABLE SQUARE TO THE SAW BLADE'S SIDE continued

4. The angle indicator on the trunnion, under the table at the rear of the machine, can be adjusted by loosening the Phillips head screw and moving the pointer into position to accurately indicate the 90°

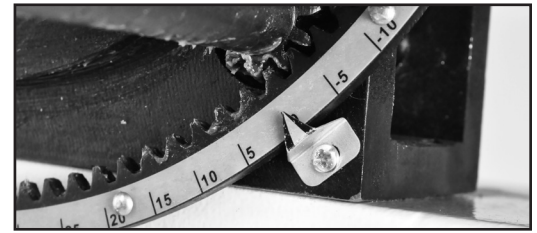

FIGURE 13

## SETTING THE TABLE SQUARE TO THE SAW BLADE'S BACK

While pre-set before shipping, if needed, the table may also be re-set at 90° to the back of the saw blade by adjusting the trunnion's micro adjustment screws.

1. On the lower Trunnion Support (#18B), slightly loosen the two Hex Bolts (#14B) that hold the support to the bandsaw frame. Fig. 14, A.
2. Set a square on the table and against the saw blade's back, flat edge.
3. Using the 3mm hex wrench, turn the rear trunnion micro adjusting hex screws (#17B) to adjust the table position. Fig. 14, B.
  - *Clockwise* will raise the trunnion & table.
  - *Counterclockwise* will lower the trunnion & table.
4. Check the table and blade angle for 90° and when achieved, re-tighten the bolts to secure the table in position.

**⚠ WARNING** THE MACHINE MUST NOT BE PLUGGED IN AND THE POWER SWITCH MUST BE IN THE OFF POSITION UNTIL ALL ADJUSTMENTS ARE COMPLETE.

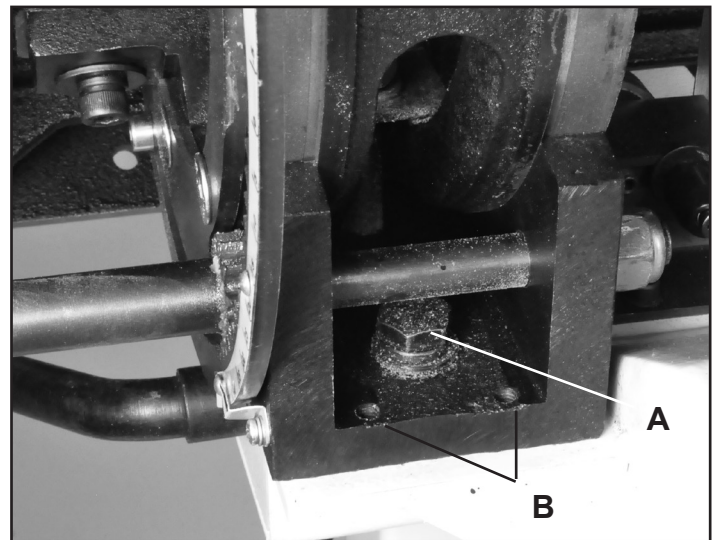

FIGURE 14

Photo of the micro adjusting screws shown with table angled for clarity.

## TRACKING THE SAW BLADE

**⚠ WARNING** Unplug the bandsaw. A blade is installed at the factory. It is recommended to check the blade tracking prior to use. Make sure the upper and lower blade guides are adjusted away from the blade and the tension scale is set to correspond to the width of the blade you are using.

1. Open both doors. At the rear of the machine, loosen the Lock Lever (#27D, FIG. 15, A) by turning it counterclockwise.
2. Turn the Blade Tracking Handle (#28D, Fig. 15 B) clockwise or counterclockwise, while at the same time carefully turning the Upper Wheel (#1F) by hand. Reference Fig. 16, on page 14. Check the tracking of the blade on the wheel through the side window (C). Make at least three rotations of the wheel or until the blade tracks centered on the wheel.

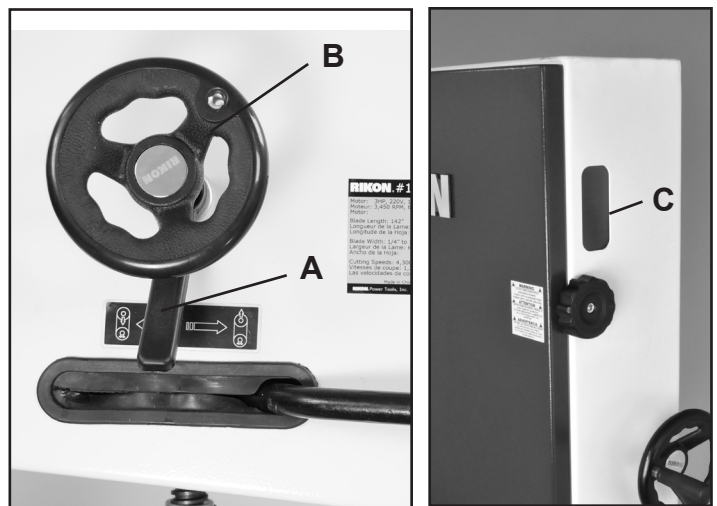

FIGURE 15

CONTINUED ON PAGE 14

# ADJUSTMENTS

## TRACKING THE SAW BLADE continued

3. Once the blade runs centered, tighten the lock lever and close the doors. For tracking of the blade on the Lower Wheel (#9F), see page 26 for instructions.

**NOTE:** the lower wheel has been pre-set at the factory and any changes made to this wheel should be after thorough reading and understanding of the instructions. Failure to do so could damage the machine.



FIGURE 16

## ADJUSTING THE BLADE TENSION

**CAUTION** Always tension the blade with the Quick Release Lever (#19D) in the “ON” position. Failure to do so could result in lack of blade tension or tension failure. Figure 17.

**NOTE:** Release / turn ‘OFF’ the Tension Lever ONLY to change the blade, or to prolong the life of the blade when the saw is not in use for extended periods.

1. To adjust the blade tension, turn the Blade Tension Handwheel (#17D, Fig. 18, A).

To tighten the tension of the blade, turn the hand wheel clockwise. Tension the blade until the Tension Indicator Arrow (#6A, Fig. 18, B) corresponds to the width of blade you are using. View the indicator Arrow through the top door’s front window.

**NOTE:** The blade tension scale may read differently due to different blade specifications from manufacturers - steel thickness, material, or variations in the welded blade length. It may be necessary to adjust the tension arrow up/down one size on blade tension scale to match your blade. Note the blade setting for the next time the same blade is used.

**General Rule** for blade tension: With the saw unplugged and the blade guard up, the saw blade should deflect about 1/4” when pressed with a finger to the side of the blade.



FIGURE 17

**WARNING** THE MACHINE MUST NOT BE PLUGGED IN AND THE POWER SWITCH MUST BE IN THE OFF POSITION UNTIL ALL ADJUSTMENTS ARE COMPLETE.

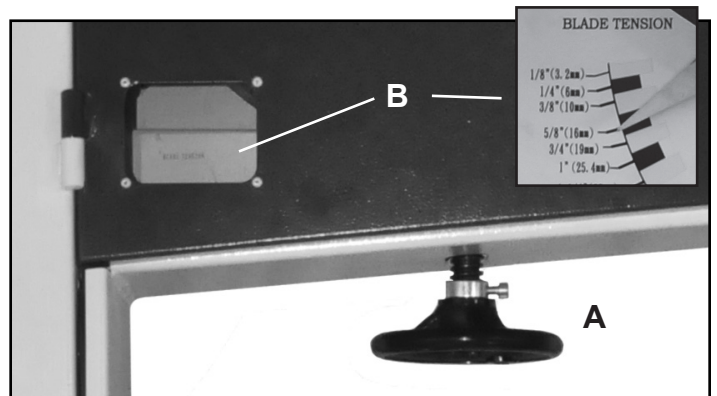
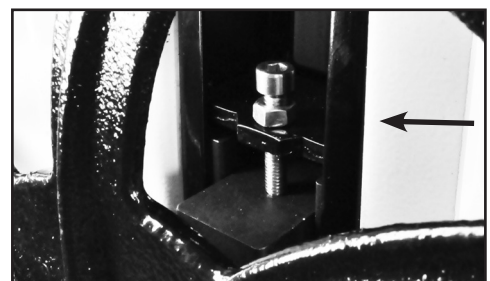

FIGURE 18

## ADJUSTING THE BLADE TENSION STOP

If you can not set full tension on a new blade, the blade is most likely welded a bit longer than the standard 153” length, and so just beyond the pre-set tensioning range of the saw. To fix this, behind the top bandsaw wheel is Set Screw (#1D). Loosen the Nut (#2D) and turn the screw upward about 1/4”, then retighten the securing nut. This will increase the blade tensioning range of the saw for your new blade.



# ADJUSTMENTS

## ADJUSTING THE BLADE TENSION INDICATOR

The Blade Tension Indicator Arrow should be checked and adjusted the first time the saw is set up and run, and whenever a new blade is installed.

The blade tension indicator should be adjusted for blades made from thicker steel, if over cut or undercut in length, or made by different manufacturers.

1. With desired tension on the blade, loosen the top adjusting Screw (#8A) with a Phillips screwdriver. Fig. 19.
2. Adjust the blade indicator up/down as needed and then re-tighten the screw.

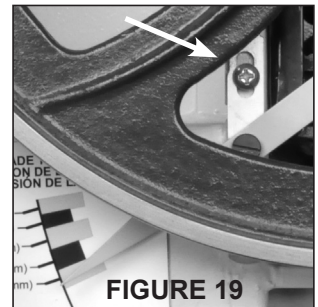

FIGURE 19

## CHANGING THE BANDSAW BLADE

**WARNING** Unplug the machine from the electrical supply to ensure that the Bandsaw will not accidentally turn on if the ON/OFF switch is bumped.

1. Release the blade tension by moving the quick release lever from the right to the left (OFF). Fig. 20.
2. Open the top and bottom wheel doors, and remove the table support pin from the table front edge, and Dust Board (#33A, Fig. 21, G) by the lower dust port.
3. Open the Hinged Door (#11C) on the blade guard by loosening the Locking Handle (#14C). Fig. 21, A.
4. Remove the saw blade from the top wheel then feed it through the upper blade guides (B), slot in the table (C), lower blade guides (D), out of the slot in the column of the machine (E), off of the bottom wheel, and then around the front rail (F).

**CAUTION** Be careful not to cut yourself on the sharp saw teeth. Wear gloves for protection.

5. When installing the new blade, reverse the steps 1-4 above. Ensure that the blade teeth are pointing downwards and towards you at the position where the blade passes through the table.
6. Center the blade on both wheels.
7. Re-tension the new blade by moving the quick release lever back to the ON position, Fig. 20, and check the blade tracking. The blade should run in the center of the wheels. Refer to “Tracking the Saw Blade” on pages 13 and 14 for more details.
8. Reset the blade guides as described in the section “Adjusting the Blade Guides” on pages 16 and 17.
9. Reset the blade tension as described in the section “Adjusting the Blade Tension” on page 14.
10. Close the hinged door on the blade guard and tighten the locking handle to keep the door closed.
11. Close and lock both the wheel doors before reconnecting the power supply.



FIGURE 20

**WARNING** THE MACHINE MUST NOT BE PLUGGED IN AND THE POWER SWITCH MUST BE IN THE OFF POSITION UNTIL ALL ADJUSTMENTS ARE COMPLETE.

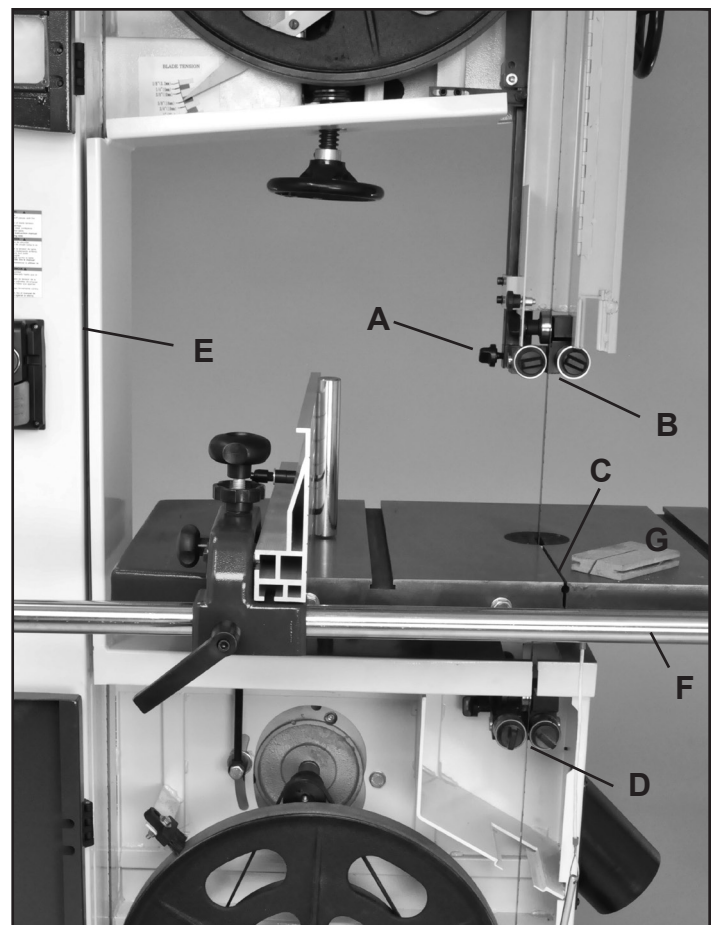

FIGURE 21

# ADJUSTMENTS

## ADJUSTING THE BLADE GUIDES

The 10-342 Bandsaw features quick-adjusting, spring loaded, ball bearing blade guides for fast and easy setting to the blades. With the bandsaw blade properly centered on the drive wheels, the guide bearings can then be set. To adjust the blade guides:

### Upper Guides:

1. Position the right and left roller guides relatively close to the blade. First, loosen their front Lock Handles (#21C, Fig 22, A). The Guide Shafts (#25C) that hold the guide bearings are spring loaded! To move the guides towards the blade, simply push the ends of the guide shafts (B), or use the front lock handles to pull the guides towards the blade. Lock the guides in place with the front handles. Fig. 22.

2. The guides should be approximately 1/16" behind the gullets of the saw blade. If they need to be moved, loosen the back Clamp Handle (#31C, Fig. 23, C) and move the Upper Guide Block (#20C, D) that holds the guides so that the guides are properly positioned behind the blade gullets. Re-tighten the handle when done. Fig. 23.

3. Set both bearing guides to within 1/32" of the saw blade - about the same thickness of a business card. Do not set the bearing guides too close, or touch the sides of the blade, as this will adversely affect the life of the saw blade and bearings.

4. Adjust the rear bearing guide (Fig. 23, E) to be just clear of the back of the saw blade. Release the guide's Locking Handle (#17C, F) and move the rear guide towards the blade by pushing the end of the Rear Guide Shaft (#27C, Fig. 24, G) located at the rear of the block. Tighten the handle when done.

### Lower Guides:

Adjusting the lower ball bearing guides, that are below the table, is similar to the steps taken for the upper guides.

1. Position the right and left roller guides close to the blade. Loosen the front Lock Handles (#38A, Fig. 25, A). Move the guides towards the blade by pushing the ends of the Guide Shafts (#42A, B), or use the front lock handles to pull the guides towards the blade. Lock the guides in place. Fig. 25.

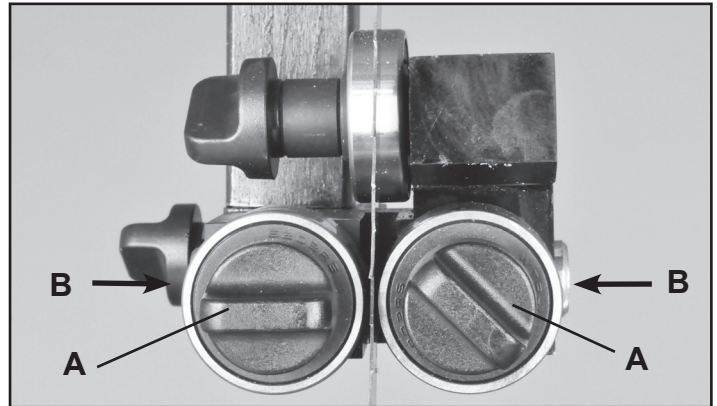

FIGURE 22 NOTE: Blade Guard removed for photo purposes

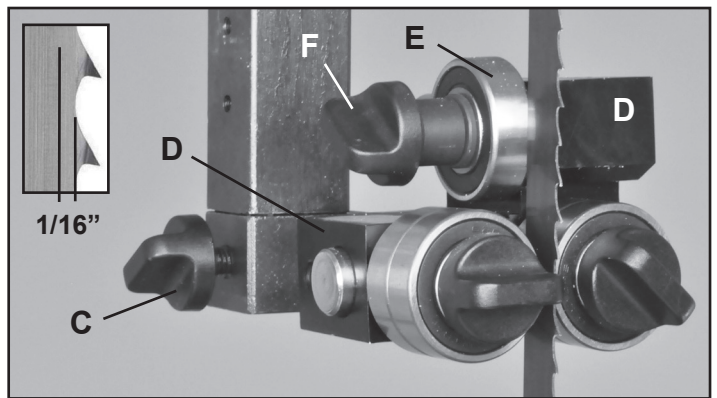

FIGURE 23 NOTE: Blade Guard removed for photo purposes

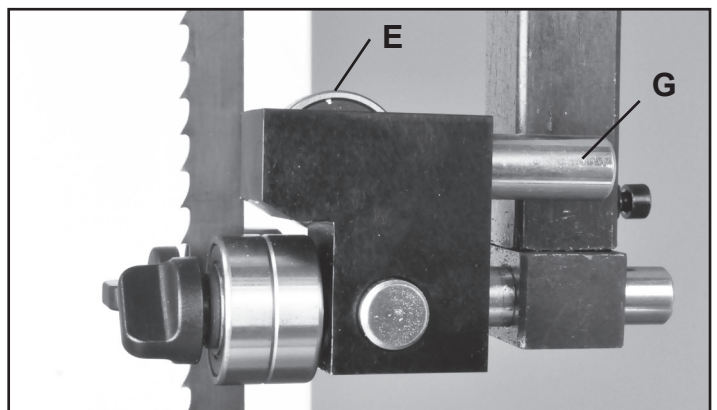

FIGURE 24 NOTE: Blade Guard removed for photo purposes

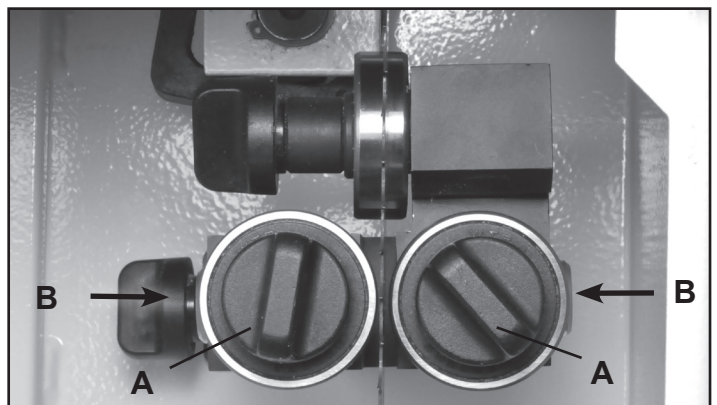

FIGURE 25

CONTINUED ON PAGE 18



# ADJUSTMENTS

## ADJUSTING THE BLADE GUIDES - continued

### Lower Guides - continued:

2. The guides should be approximately 1/16" behind the gullets of the saw blade. If they need to be moved, loosen the Lock Handle (#47A, Fig. 26, A), located to the left of the Lower Guide Block (#44A, B), and move this block that holds the guides so that the guides are properly positioned behind the blade gullets. Re-tighten the lever handle when done.



FIGURE 26

3. Set both bearing guides to within 1/32" of the saw blade's sides - about the same thickness of a business card. Do not set the bearing guides too close, or touch the sides of the blade, as this will adversely affect the life of the blade and bearings.

4. Adjust the rear bearing guide to be just clear of the back of the saw blade. Release the guide's Locking Handle (Fig. 27, C) and move the rear guide towards the blade by pushing the end of the Rear Guide Shaft (#49A). This shaft extends through the bottom frame for easy access. Tighten the handle when done.

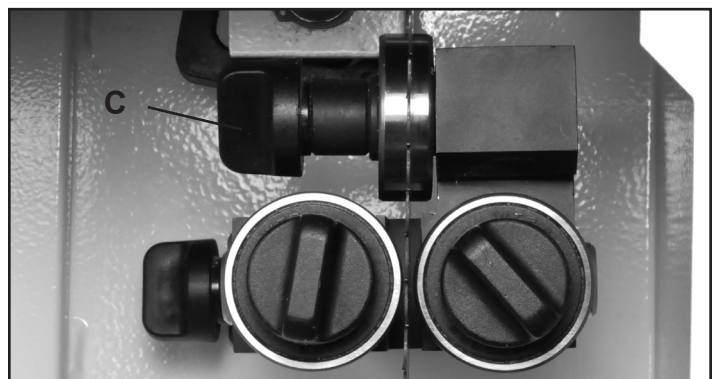

FIGURE 27 NOTE: Blade Guard removed for photo purposes

## ADJUSTING THE BLADE GUIDE & GUARD

**NOTE:** Before cutting, set the upper guide bearings approximately 1/4" above the top surface of the work piece. This will give the best blade control. Fig. 28.

1. Loosen the Guidepost Lock Knob (#1C, Fig. 29A) and turn the Guidepost Handle (#38C, Fig. 30, B) to raise or lower the guide post/upper blade guide assembly to the desired height.

A measurement scale has been supplied on the right side of the guide post for quick reference on the height of the guide bearings above the table surface.

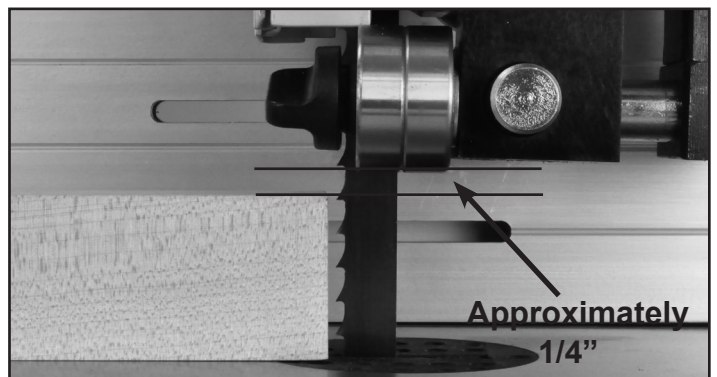

FIGURE 28

2. When the guide bearings are in proper position, re-tighten the guidepost lock knob.

**NOTE:** The guide post is pre-set at the factory to aligned vertical with the bandsaw blade. If the guide post setting ever needs slight adjustment:

3. Open the top door and lower the blade guard all the way down to the table to access the Guide Bracket (#4C). Fig. 31.

4. Loosen the four Hex Bolts (#2C) located at the rear of the top frame. (Fig. 29, C). This will allow the

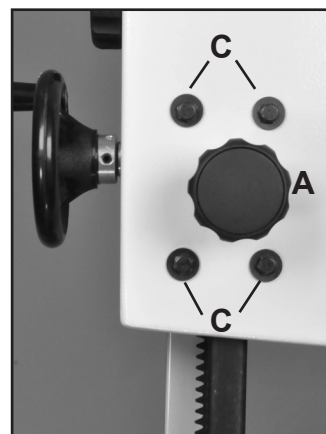

FIGURE 29

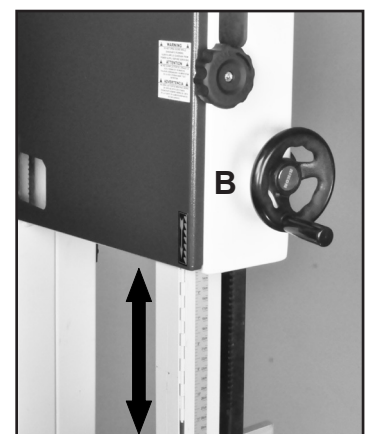

FIGURE 30

CONTINUED ON PAGE 18

# ADJUSTMENTS

## ADJUSTING THE BLADE GUARD - continued

guide post to be shifted/angled a bit left or right to correct any positioning issues.

5. There are also four Set Screws (#5C) set in the rear of the guide bracket near the corners. If the guard post needs to be angled slightly towards the front or back of the table, or even twisted on an angle, make the adjustment with these screws. Fig. 31.

- Advancing the top two set screws will angle the post towards the rear of the table.
- Advancing the bottom two set screws will angle the post towards the front of the table.
- Setting the two left or right screws will angle the post to the right or left.

6. When the post is adjusted vertical, tighten the four hex bolts that were loosened in step 4.

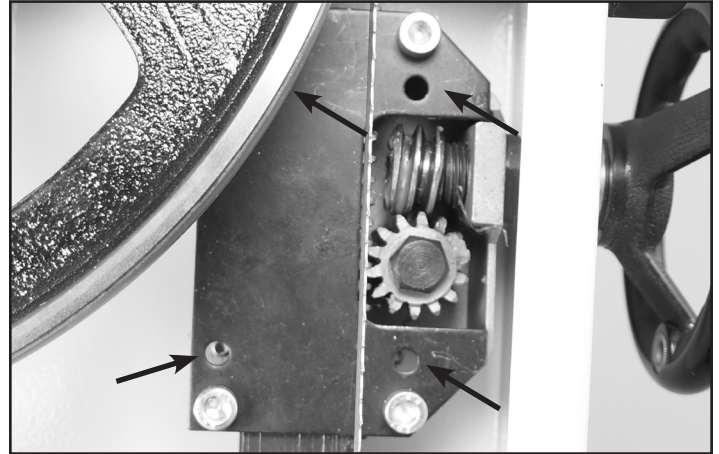

**FIGURE 31** NOTE: Gear Guard removed for photo purposes

**⚠ WARNING** THE MACHINE MUST NOT BE PLUGGED IN AND THE POWER SWITCH MUST BE IN THE OFF POSITION UNTIL ALL ADJUSTMENTS ARE COMPLETE.

## ADJUSTING THE RIP FENCE FOR DRIFT

The 10-342 Bandsaw features an innovative fence system that will easily adjust to eliminate 'drift', and bring the fence back to being parallel to the blade. Plus, it allows quick changing of the fence from a vertical to horizontal position, or for use to the left or right of the blade. To adjust the fence for drift:

1. Loosen the side Handle (#7E, Fig. 32, A) which holds the rip fence against the Fence Carrier (#9E, B).
2. Loosen the Locking Knob (#2E, Fig. 32, C).
3. Turn the top Adjusting Handle (#1E, D) to position the fence left or right as needed to align it parallel to the blade and miter saw slots in the table. The handle turns a Cam (#4E, E) that presses against the fence and pivots it as needed.
4. Once the fence is set, tighten the Handle and Knob that were loosened in steps 1 and 2.

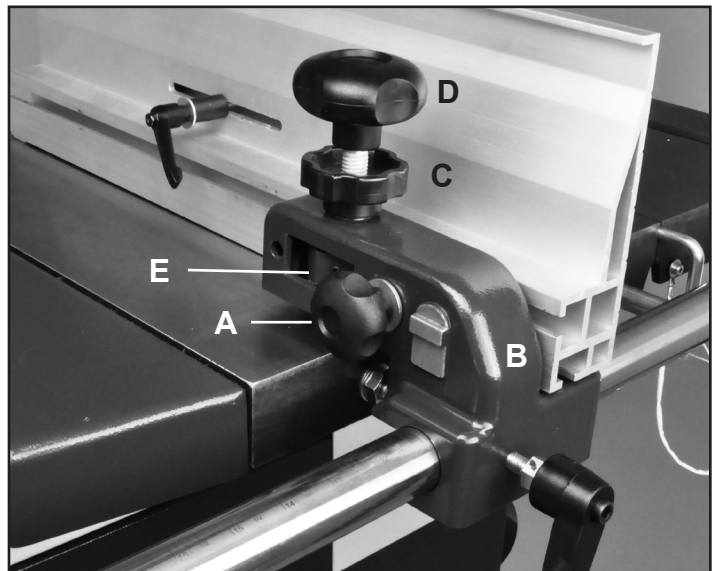

**FIGURE 32**

## ADJUSTING THE FENCE 90° TO THE TABLE

Check that the fence is 90 degrees to the table using a suitable square. If adjustments are required, raise or lower either side of the fence's Guide Rail until the fence body is 90 degree to the table. Once set at 90 degrees, fully tighten the fence bar nuts. FIG. 33. See page 11 for the guide rail installation process.

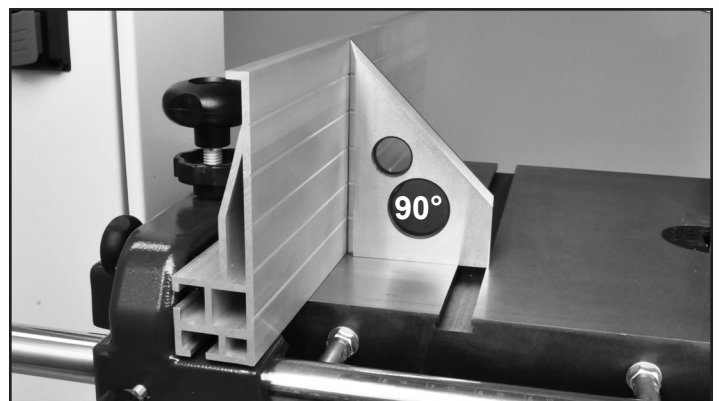

**FIGURE 33**

# ADJUSTMENTS

## ADJUSTING THE FENCE TO THE TABLE

Check that the fence is lying flat, or parallel to the table surface. The gap between the table and the bottom of the fence should be equal along the whole length of the fence. If a slight adjustment is necessary, the front rail will need to be adjusted - moving it up or down to raise or lower the fence distance over the table. Fig. 34.

Refer to page 11 for instructions on the mounting and re-positioning of the front fence rail.

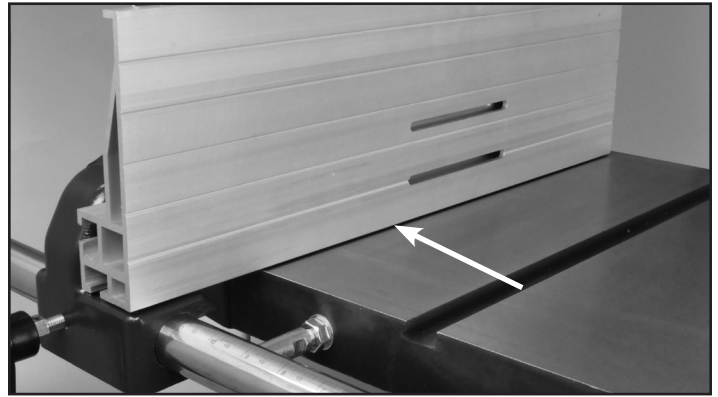

FIGURE 34

## ADJUSTING THE FENCE ON THE CARRIER

The fence can be changed from a vertical position to a horizontal position, or from its mounting on the left side of the blade to the right with simple adjustments of the carrier's handles and hardware.

### To change the fence from vertical to horizontal:

1. Loosen the side Handle (#7E, Fig. 35, A) which holds the rip fence against the Fence Carrier (#9E, B).

2. Slide the fence forward to remove it from the carrier's Sliding Block (#11E, Fig. 35, C).

3. Turn the fence down to its horizontal position and slide it back onto the carrier. The bottom of the fence is slotted to mount on the sliding block, and position itself on the small, raised key (Fig. 35, D) on the side of the carrier. Fig. 36.

4. Once in place, retighten the side handle to secure the fence in position on the carrier.

5. Check the fence for drift, and make corrections if needed per instructions on page 18.

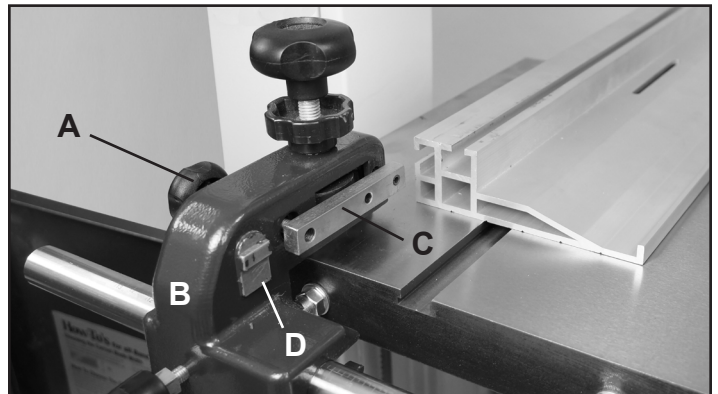

FIGURE 35



FIGURE 36

### To change the fence from the left side of the carrier to the right side for using the rip fence to the right of the blade:

1. Loosen the side Handle (#7E, Fig. 35, A) which holds the rip fence against the Fence Carrier (#9E, B).

2. Slide the fence forward to remove it from the carrier's Sliding Block (#11E, C). Move the carrier on the front rail to the right side of the table and blade.

3. Fully unscrew the side handle from the sliding block and reassemble the parts on the opposite, left

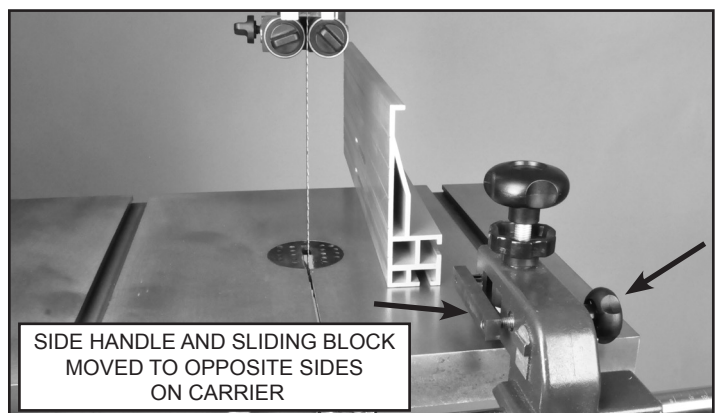

FIGURE 37

CONTINUED ON PAGE 20

# ADJUSTMENTS

side of the carrier. Then rotate the fence 180° end-to-end and slide it back onto the carrier. Fig. 37 & 38.

4. Once in place, retighten the side handle to secure the fence in position on the carrier. Fig. 38.

5. Check the fence for drift, and make corrections if needed per instructions on page 18.

**⚠ WARNING** THE MACHINE MUST NOT BE PLUGGED IN AND THE POWER SWITCH MUST BE IN THE OFF POSITION UNTIL ALL ADJUSTMENTS ARE COMPLETE.

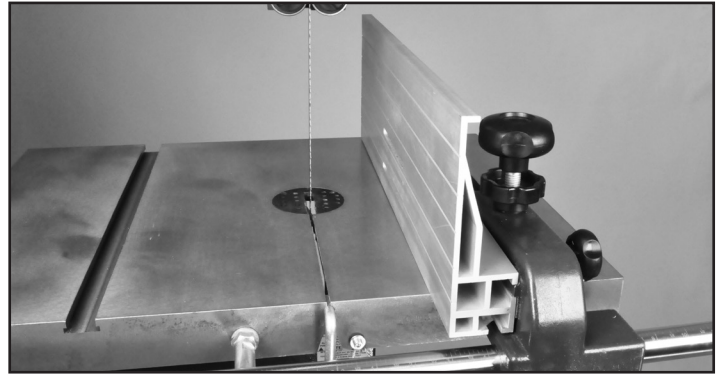

FIGURE 38

## ADJUSTING THE DRIVE BELT TENSION

Check the Drive Belt (#10F, FIG. 39, A) tension with thumb pressure. The drive belt should not give more than 3/8" TO 1/2" in the center. DO NOT over tension the belt as this can put excessive, damaging pressure on the belt, pulleys and motor. Fig. 40.

To adjust the tension:

1. Loosen the two Hex Bolts (#25A, 27A, Fig. 39, B) that secure the motor to the frame.
2. Loosen the Hex Nut on the top of the Motor Pulling Rod (#26A, Fig. 39, C). The motor should now be loose to move downward for adjusting the belt.
3. For *less tension* on the drive belt, push the motor downward.
4. For *more tension* on the drive belt, lift the motor upwards. NOTE: There is a second hex nut on the motor pulling rod that is located *under* the frame. This second hex nut (Fig. 39, D) must be loosened to allow the motor to be lifted upwards.
5. When the belt tension is correct, tighten all the motor mounting nuts from steps 1, 2 and 4 above.

SEE PAGE 23 FOR INSTRUCTIONS ON CHANGING THE DRIVE BELT.

## LEVELING THE TABLE INSERT

The table insert has an innovative, built-in micro adjustment feature to use if the insert sits too high or too low in the table seat. If the insert is resting *above* the table, turn the hex screws counter-clockwise to lower the insert. If the insert is sitting *below* the table surface, turn the hex screws clockwise to raise the insert level with the table surface. Fig. 41.

**CAUTION:** Having the insert below the table surface could cause the workpiece to get stuck on the lip of the table seat behind the blade, stopping your cut.

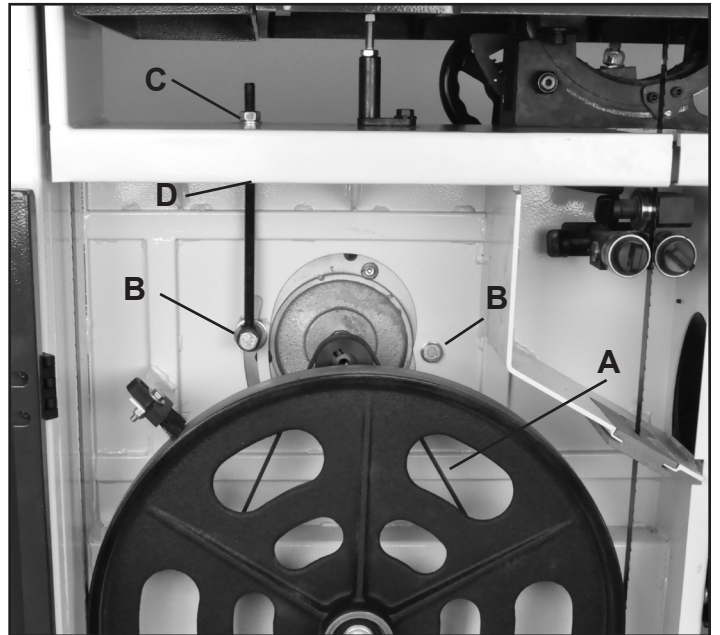

FIGURE 39

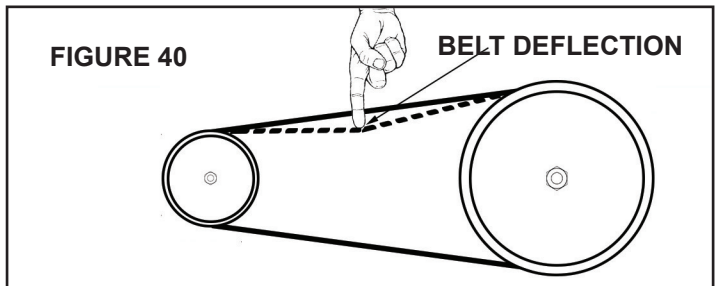

FIGURE 40

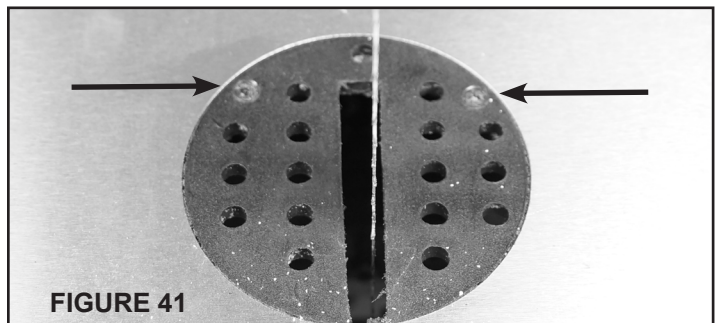

FIGURE 41

# OPERATION

## BASIC OPERATION

- The blade cuts on a continuous down-stroke. Never start the saw with the workpiece in contact with the saw blade.
- With both hands, firmly hold the workpiece down on the table, and feed it slowly towards the blade, putting only light pressure on it, and keeping your hands away from the blade.
- Keep your fingers away from the blade. Use a push stick whenever working close to the blade.
- For best results the blade must be sharp. A dull blade will not cut correctly, especially when straight cutting, and causes excess pressure to be applied on the rear guide bearings.
- Select the right blade for the job, depending on the thickness of the wood and the cut to be made. The thinner and harder the wood, the finer the teeth of the blade should be. Use a fine tooth blade for cutting sharp curves.
- The machine is especially suited for cutting curves, but will also make straight cuts. When cutting, follow the design marked out by pushing and turning the workpiece evenly into the blade.
- Do not attempt to turn the workpiece without pushing it, as this may cause the workpiece to get stuck, or bend the blade. For straight cuts, use the fence provided to feed the workpiece along the blade slowly and in a straight line. Use a miter gauge for cross-cut or angle cutting.
- See page 6 for more operation information.

## ON/OFF SWITCH

To operate the saw, Press the round “ON” button in to its full depth to turn the saw on. There should be a ‘click’ to indicate the ‘on’ contact is made.

Once work is finished, hit the safety paddle switch marked “STOP” to turn the saw off. FIG. 42.



FIG. 42

## RE-SAWING

A re-saw guide bar is supplied to help correct any blade wandering during certain re-sawing operations.

For re-sawing, attach the re-saw bar to the slot on the fence. Position the re-saw bar so that it is aligned with the front of the blade. Draw a reference line down the workpiece. Use the bar as a pivot point, angling the wood left or right while against the bar, to follow the line through the cut. FIG. 43.

**Note:** The re-saw bar is not needed for all re-saw operations. Proper blade tension and selection, as well as proper guide set up, will allow re-sawing flat stock against the fence without the use of the re-saw bar.

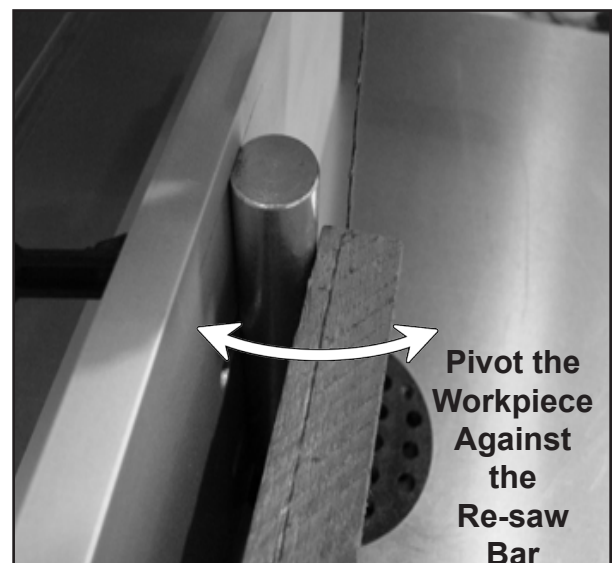

FIG. 43

## OPERATION

### ELECTRICAL OUTLET

On the rear of the bandsaw column below the tool holder, a 110V electrical outlet has been added to the machine for your working convenience. This outlet can be used with work lights (with magnetic bases or clips) to illuminate the work table and blade, for radios, charging phones or tablets, etc. FIG. 44.

**CAUTION:** Make sure that the cords of these devices do not interfere with any parts of the bandsaw.



FIGURE 44

## WIRING DIAGRAM

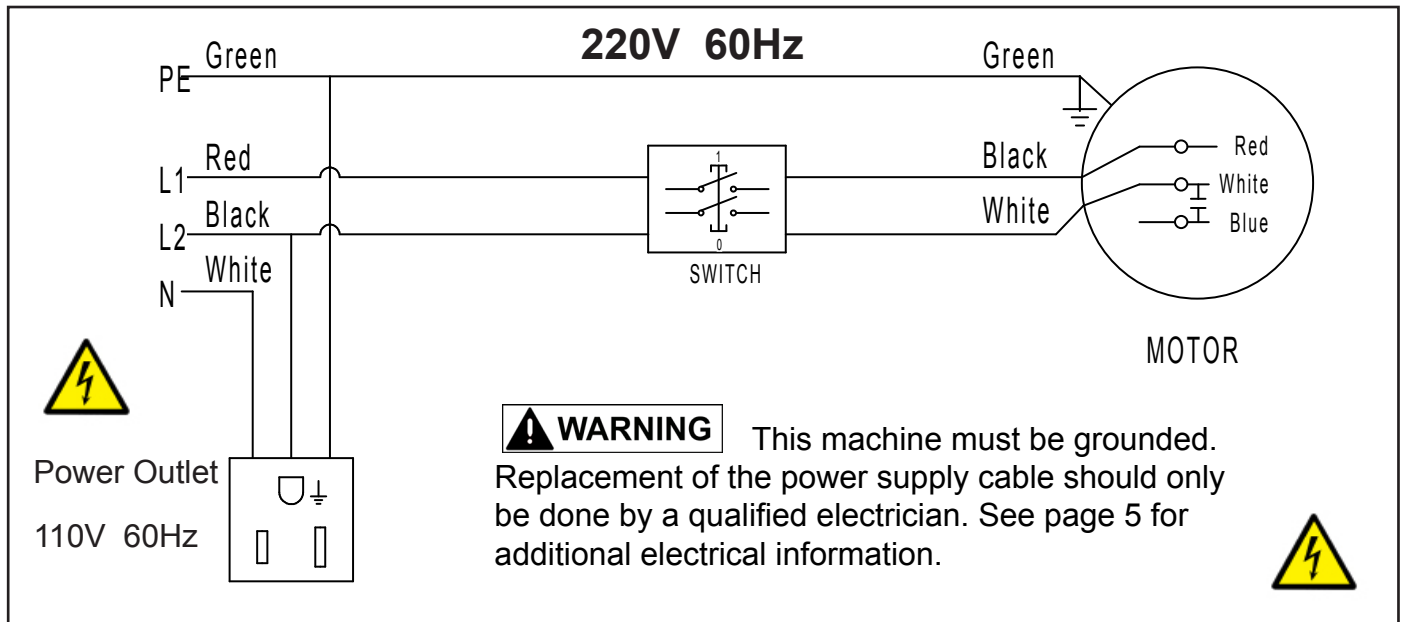

## MAINTENANCE

**CAUTION** BEFORE CLEANING OR CARRYING OUT MAINTENANCE WORK, DISCONNECT THE MACHINE FROM THE POWER SOURCE (WALL SOCKET). NEVER USE WATER OR OTHER LIQUIDS TO CLEAN THE MACHINE. USE A BENCH BRUSH. DO NOT USE COMPRESSED AIR NEAR BEARINGS. REGULAR MAINTENANCE OF THE MACHINE WILL PREVENT UNNECESSARY PROBLEMS.

1. Keep the table clean to ensure accurate cutting.
2. Keep the outside of the machine clean to ensure accurate operation of all moving parts and prevent excessive wear.
3. Keep the ventilation slots of the motor clean to prevent it from overheating.
4. Keep the inside of the machine (near the saw blade, etc.) clean to prevent accumulation of dust. Use dust collection, if possible.
5. To prolong the life of the blade, when the bandsaw is not in use for extended periods, release the blade tension. Before reusing the bandsaw, ensure that the blade is re-tensioned and tracking is checked.
6. Keep the guide bearings free of dust, and clean the guide bearing assemblies frequently.

# MAINTENANCE

**⚠ WARNING:** THE MACHINE MUST NOT BE PLUGGED IN AND THE POWER SWITCH MUST BE IN THE OFF POSITION UNTIL ALL ADJUSTMENTS ARE COMPLETE.

## CHANGING THE MOTOR DRIVE BELT

Refer to “Frame Assembly” parts diagram on page 28, and “Motor & Drive Wheel Assembly” page 37.

1. Before changing the belt, make sure that the bandsaw is unplugged from the power source.
2. Release the saw blade tension from the drive belt by turning the quick release blade tension lever.
3. Release the drive belt tension by using the belt tension. See page 20 for Instructions.
4. Remove the lower wheel (Wheel Assembly, Part #9F) by removing the hex head bolt and washer (#7F, 6F) in the middle of the wheel’s hub. Carefully slide the lower wheel off of the lower wheel shaft, and at the same time remove the saw blade from this wheel.

**⚠ CAUTION** Be careful not to cut yourself on the sharp saw teeth. Wear gloves for protection.

5. Remove the old drive belt from the wheel’s pulley, and install the new belt. Make sure the ribs in the drive belt are seated correctly in the pulley before reassembling and tensioning the drive belt.
6. Reverse the procedure to re-assemble the saw parts. Tension the drive belt until there is 3/8” to 1/2” of deflection. See page 20 for instructions on ‘Belt Tensioning’.

## CHANGING BANDSAW TIRES

Use a putty knife to get underneath the tire and pull it up and away from the wheel. Work the putty knife all the way around the wheel to loosen the tire. Then, use the putty knife as leverage to flip the tire over and off of the wheel. Clean the inside of the groove, removing any dirt, debris or cement with lacquer thinner.

Soak the replacement tire in warm water to make it more flexible. Dry the tire, and while it is still warm, lay it on top of the wheel. Start by setting the tire into the wheel groove at the top of the wheel. Using a putty knife, work the new tire around the wheel, making sure not to slice the tire. If rubber cement is to be used as a binder, make sure to distribute it evenly. Having high spots between the wheel and the tire will cause a vibration and effect blade tracking.

# NOTES

Use this section to record maintenance, service and any calls to Technical Support.

---

---

---

---

---

---

---

---

---

---

## How-To's for all Band Saw Blades

### Choosing the Correct Blade Width

Blade width is measured from the tips of the teeth to the back edge of the blade as shown above. The instructions for the particular machine being used should be followed when selecting blade width.



If no such instructions are provided, blade width should be determined with the following guidelines:

For Cut-Off Sawing, the blade should be as wide as the machine will allow. The wider the band is, the straighter the cut will be. Faster feeding can be achieved.

For Contour Sawing, the blade should be as wide as the machine allows, but still narrow enough so that it can cut the desired shape (radius). Minimum dimensions for different cutting radii are shown on the chart at right.

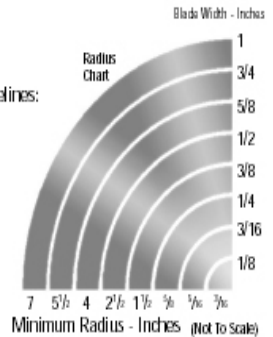

### How To Choose The Correct Number Of Teeth Per Inch (TPI)

The number of teeth per inch (TPI) is important in obtaining the finish desired and the proper feed rate. A coarse tooth blade (2, 3 TPI) should be used for resawing wood and cutting thicker stock up to 8". A fine toothed blade (18 to 32 TPI) should be used for thinner metals and plastics under 1/4". For general cutting of 3/4" wood 4 TPI will provide a fast cut and 14 TPI will cut slow, but leave a smoother finish.

When Selecting TPI remember:

- More TPI give a smoother but slower cut
- Fewer TPI allow a faster cut with a slightly rougher finish
- At least three teeth must be in the workpiece—the chart to the right will help you decide.

TPI	Minimum Material Thickness
32	3/32"
24	1/8"
18	5/32"
14	1/4"
10	5/16"
8	3/8"
6	1/2"
4	3/4"
3	1"
2	1-1/2"

It is important to know the SFM for the various speed settings of your band saw, so that you can select the proper speed for cutting wood or other materials. Check the operator's manual of your band saw to determine the SFM or use the following procedure:

1. Determine the RPM: check the operator's manual or clock the revolutions per minute of the wheels with a tachometer or revolution counter.
2. Measure the diameter of the drive wheel in inches and multiply by .262 to obtain the wheel circumference. The RPM times circumference equals the surface speed of the blade.  
 $RPM \times \text{diameter in inches} \times .262 = SFM.$

**Note:** Spring Steel Wood Cutting Band Saw Blades should never be operated at surface speeds above 3000 SFM. Carbon Hard Edge Flexible Back Band Saw Blades may be run up to 8000 SFM.

### Installing your Band Saw Blade

1. Unplug the saw, then loosen the tension on the upper wheel. With all the blade guides backed off, slip the new blade around the wheels and then tension it.
2. When you have tensioned the blade enough to keep it on the wheels, track it by turning the upper wheel with one hand while adjusting the tilt of the wheel's axis with the other hand. The blade should ride in the middle of the rim. **Never track the blade with the motor running and the cover open.**
3. Next, adjust the blade guides; first the thrust bearings: upper and lower, then the left and side guides.
4. Use a square to make sure you are not pushing the blade out of line and place a piece of white paper between the blade guide and the blade to allow for clearance.

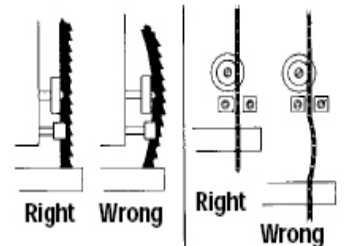

### Diagnosing Problems

#### 1. Premature and Excessive Tooth Wear

- Feed pressure too light, increase it.
- Lower band velocity.
- Improper tooth selection, use a finer pitch.
- Improper break-in with new band. Velocity and feeding should be reduced the first few cuts.
- Teeth are running the wrong direction.
- Be sure teeth are pointing in proper direction.
- Incorrect saw guide insert size for the band, allowing them to strike teeth

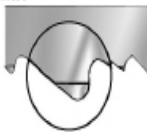

#### 2. Blade Vibration

- Increase or decrease band velocity.
- Increase tension of band.
- Teeth too coarse for workpiece.
- Increase feed pressure.
- Material not securely held.

#### 3. Gullets Loading

- Teeth too fine for workpiece - use a coarser pitch.
- Decrease band velocity.

#### 4. Band Stalls in Work

- Feed pressure too great - decrease feed.
- Teeth too coarse, use finer tooth blade

#### 5. Premature Blade Breakage

- Thickness of blade too heavy for diameter of wheels and speed of machine
- Increase or decrease velocity
- Check wheels for defects
- Teeth too coarse for workpiece - use a finer pitch
- Decrease blade tension - decrease feeding force
- Brittle weld - increase annealing period, decreasing heat gradually
- Check for proper adjustment of band guides, saw guides, saw guide inserts, and back-up bearings.



#### 6. Blade Making Belly-Shaped Cuts

- Increase tension.
- Adjust guides closer to workpiece.
- Teeth too fine - use a coarse pitch.
- Decrease feed force.
- Teeth dull.



#### 7. Tooth Strippage

- Teeth too coarse for workpiece.
- Material not securely held.
- Too much feed pressure - reduce for good chip curl.
- Band velocity too low - increase speed.



#### 8. Band Develops a Negative Camber

- Band is riding on saw guide backup bearing too heavily. Adjust band for alignment on top and bottom wheels.
- Check band wheel alignment.



#### 9. Blade Not Running True Against Saw Guide Backup Bearing

- If clicking noise against saw guide backup bearing, remove burr on band.
- Check band wheel alignment.
- Check saw guide backup bearing for wear, replace if necessary
- Weld not in proper alignment. Reweld blade straight and true.



#### 10. Cutting Rate Too Slow

- Increase band velocity.
- Increase feed pressure.
- Use a coarser pitch.

#### 11. Blade Leading In Cut

- Reduce feed pressure or rate.
- Check adjustments and wear of saw guides or rollers.
- Lack of band tension.
- Tooth set damage.



#### 12. Premature Loss of Set

- Improper width selection - check chart for correct width for radius cutting.
- Reduce band velocity.

#### 13. Band Develops Positive Camber

- Decrease force.
- Use a coarser pitch to increase tooth penetration.
- Adjust saw guides closer to work.



#### 14. Band Develops Twist

- Wrong width for radius being cut - choose a narrower blade.
- Binding in cut - decrease feed pressure.
- Decrease band tension.
- Adjust saw guides further from workpiece.



#### 15. Finished Cut Surface Too Rough

- Improper tooth selection - choose a finer pitch.
- Increase band velocity.
- Decrease feed rate.



#### 16. Band Scoring (side wear or grooving)

- Check for wear on saw guide inserts.
- Too much pressure on saw guide inserts.
- Check alignment of saw guides - be sure they are square to front vise. Replace or clean guides.



#### 17. Burring or Mushrooming of Blade Back Edge

- Increase tension and adjust guides.
- Check contact between blade and back edge rollers.
- Reduce feed pressure.
- Use coarser pitch blade.
- Use finishing stone.





# TROUBLESHOOTING

**⚠ WARNING** FOR YOUR OWN SAFETY, ALWAYS TURN OFF AND UNPLUG THE MACHINE BEFORE CARRYING OUT ANY TROUBLESHOOTING.

TROUBLE	PROBABLE CAUSE	REMEDY
The machine does not work when switched on.	<ol style="list-style-type: none"> <li>1. No power supply.</li> <li>2. Defective switch.</li> </ol>	<p>Check the cable for breakage. Contact your local dealer for repair.</p>
The blade does not move with the motor running.	<ol style="list-style-type: none"> <li>1. The quick release lever or blade tension handwheel has not been tightened.</li> <li>2. The blade has come off one of the wheels.</li> <li>3. The saw blade has broken.</li> <li>4. The drive belt has snapped.</li> </ol>	<p>Switch off the motor, tighten the quick release lever or blade tension handwheel.  Open the hinged door and check.  Replace the blade. Replace the belt.</p>
The blade does not cut in a straight line.	<ol style="list-style-type: none"> <li>1. Fence for cutting not used.</li> <li>2. Too fast feed rate.</li> <li>3. The blade teeth are dull or damaged.</li> <li>4. Blade guides not suitably adjusted.</li> </ol>	<p>Use a fence. Put light pressure on the workpiece &amp; make sure the blade does not bend. Use a new blade.  Adjust the blade guides (see the section on page 16 and 17).</p>
The blade does not cut, or cuts very slowly.	<ol style="list-style-type: none"> <li>1. The teeth are dull, caused by cutting hard material or long use.</li> <li>2. The blade was mounted in the wrong direction.</li> </ol>	<p>Replace the blade, use a 6 T.P.I. blade for wood and soft materials. Use a 14 T.P.I. blade for harder materials. A 14 T.P.I. blade always cuts slower due to the finer teeth and the slower cutting performance.  Fit the blade correctly.</p>
Sawdust builds up inside the machine.	<ol style="list-style-type: none"> <li>1. This is normal.</li> </ol>	<p>Clean the machine regularly. Open the hinged door and remove the sawdust with a vacuum cleaner.</p>
Sawdust inside the motor housing.	<ol style="list-style-type: none"> <li>1. Excessive dust build-up on the machine exterior components.</li> </ol>	<p>Clean the ventilating slots of the motor with a vacuum cleaner. From time to time remove the sawdust to prevent it from being sucked into the housing.</p>
The machine does not cut at 45° or 90° angles.	<ol style="list-style-type: none"> <li>1. The table is not at right angles to the blade.</li> <li>2. The blade is dull or too much pressure was put on the workpiece.</li> </ol>	<p>Adjust the table.  Replace the blade or put less pressure on the workpiece.</p>
The blade cannot be properly positioned on the bandwheels.	<ol style="list-style-type: none"> <li>1. The blade tracking knob hasn't been properly adjusted.</li> <li>2. Inferior blade.</li> <li>3. The wheels are not in alignment.</li> </ol>	<p>Adjust the tracking knob (see page 13). Replace the blade. Adjust the lower wheel (see pages 26 &amp; 27) Contact Technical Support @ 877-884-5167 or techsupport@rikontools.com.</p>

For parts or technical questions contact: techsupport@rikontools.com or 877-884-5167.

# TROUBLESHOOTING

## LOWER WHEEL ADJUSTMENTS

The following instructions will correct common blade issues related to the lower wheel's alignment in relation to the upper wheel. These adjustments will correct the blade position on the lower wheel and blade oscillation (wobble). These are critical adjustments which affect the performance and accuracy of the bandsaw.

**CAUTION** PLEASE READ AND UNDERSTAND THESE STEPS THOROUGHLY BEFORE MAKING ANY ADJUSTMENTS. FAILURE TO DO SO COULD DAMAGE THE MACHINE.

Please contact a tech support representative if you have questions before attempting these adjustments. RIKON Tech Support 877-884-5167 techsupport@rikontools.com

Release the blade tension completely before making any lower wheel adjustments. Pressure must be released on the lower wheel to allow proper adjustments and to avoid damaging the machine.

If the blade is not running true, or it is not running on center of the lower wheel but is correct on the upper wheel, then an adjustment to the wheel hub on the rear of the bandsaw is required.

The numbers shown on the rear hub photo represent the positions on a clock face.

**NOTE:** To help identify the extent of rotation on a bolt, mark a black dot on the edge of the bolt as a visual indicator.

*If a blade is tracking forward on the lower wheel toward the door, follow these correction steps:*

- 1.) De-tension the saw blade.
- 2.) Loosen 9 o'clock shaft bolt to take pressure off the shaft.
- 3.) Loosen 12 o'clock shaft bolt one half rotation.
- 4.) Tighten the 6 o'clock shaft bolt until the shaft touches the 12 o'clock adjusting bolt.
- 5.) Lock all three shaft bolts.
- 6.) Re-tension the saw blade and set the upper wheel to plumb by adjusting the tracking knob. Spin the upper wheel by hand and track the blade.
- 7.) Repeat if further adjustment is necessary.

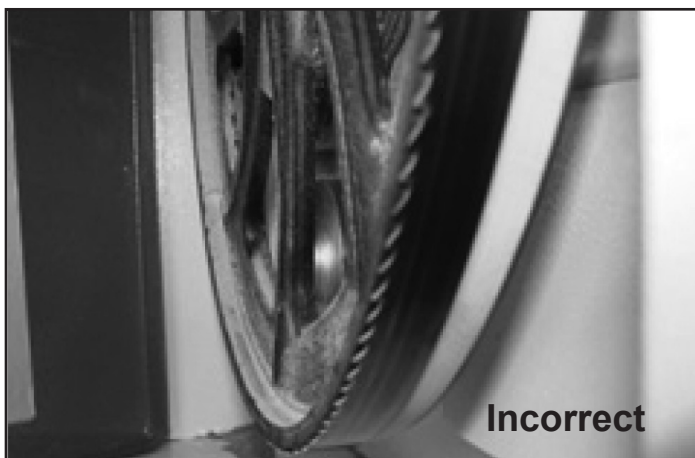
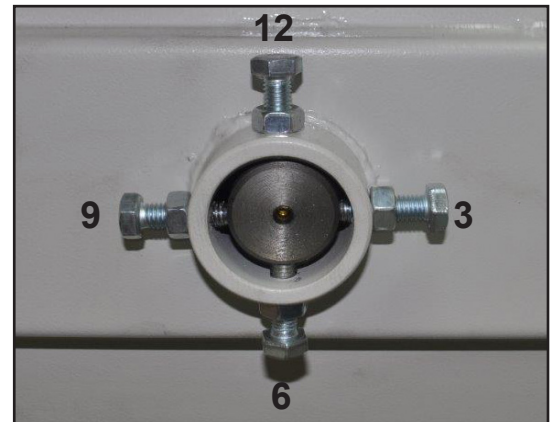

## TROUBLESHOOTING

If a blade is tracking on the rear of the lower wheel away from the door, follow these steps:

- 1.) De-tension the saw blade.
- 2.) Loosen 9 o'clock shaft bolt to take pressure off the shaft.
- 3.) Loosen 6 o'clock shaft bolt one half rotation.
- 4.) Tighten the 12 o'clock shaft bolt until the shaft touches the 6 o'clock adjusting bolt.
- 5.) Lock all three shaft bolts.
- 6.) Re-tension the saw blade and set the upper wheel to plumb by adjusting the tracking knob. Spin the upper wheel by hand and track the blade.
- 7.) Repeat if further adjustment is necessary.

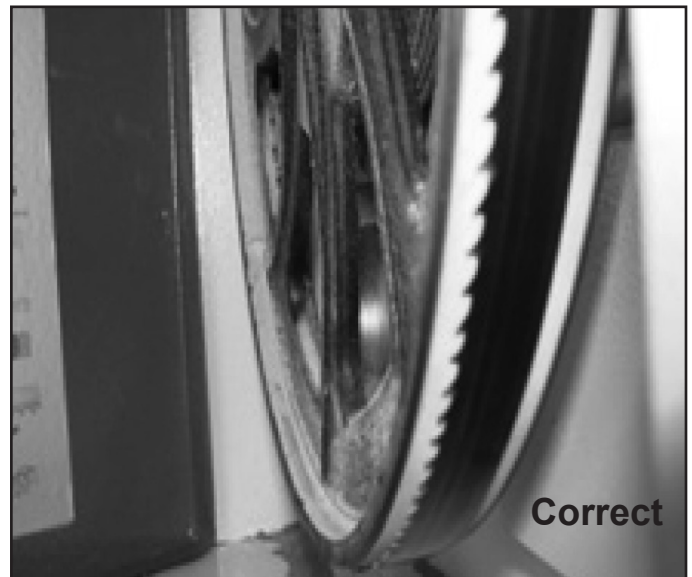

If a blade is moving back and forth (wobbling) follow these steps:

First, check the bandsaw blade to insure that it has been welded correctly, so that the blade's back is in proper alignment - flat (if it is laid down on a table surface).

If the blade is welded true, then adjustment to the wheel hub on the rear of the bandsaw is required.

- 1.) De-tension the saw blade.
- 2.) Loosen 6 o'clock shaft bolt to take pressure off of the shaft.
- 3.) Loosen 9 o'clock shaft bolt one half rotation.
- 4.) Tighten the 3 o'clock shaft bolt until the shaft touches the 9 o'clock adjusting bolt.
- 5.) Lock all three shaft bolts.
- 6.) Re-tension the saw blade and set the upper wheel to plumb by adjusting the tracking knob. Spin the upper wheel by hand and track the blade.
- 7.) Start the bandsaw and check blade movement.
- 8.) If movement has diminished then continue with the adjustment.
- 9.) If movement is worse, reverse the adjustments in steps 3 and 4.

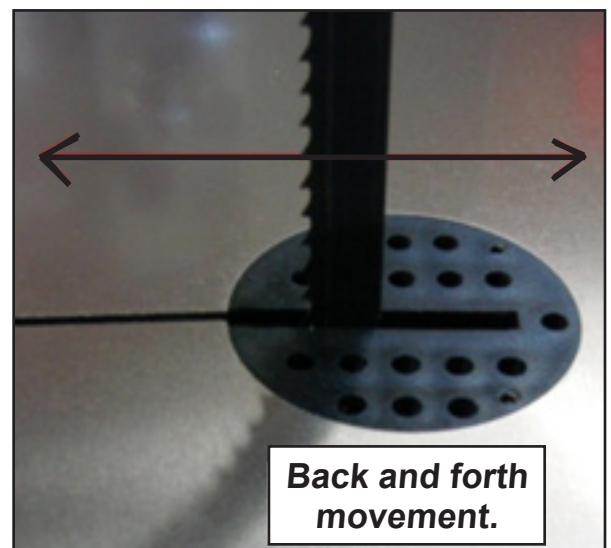

**NOTE:** Please reference the Manufacturer's Part Number when calling for Replacement Parts. For Parts under Warranty, the Serial Number of your machine is required.

# FRAME ASSEMBLY SHEET A

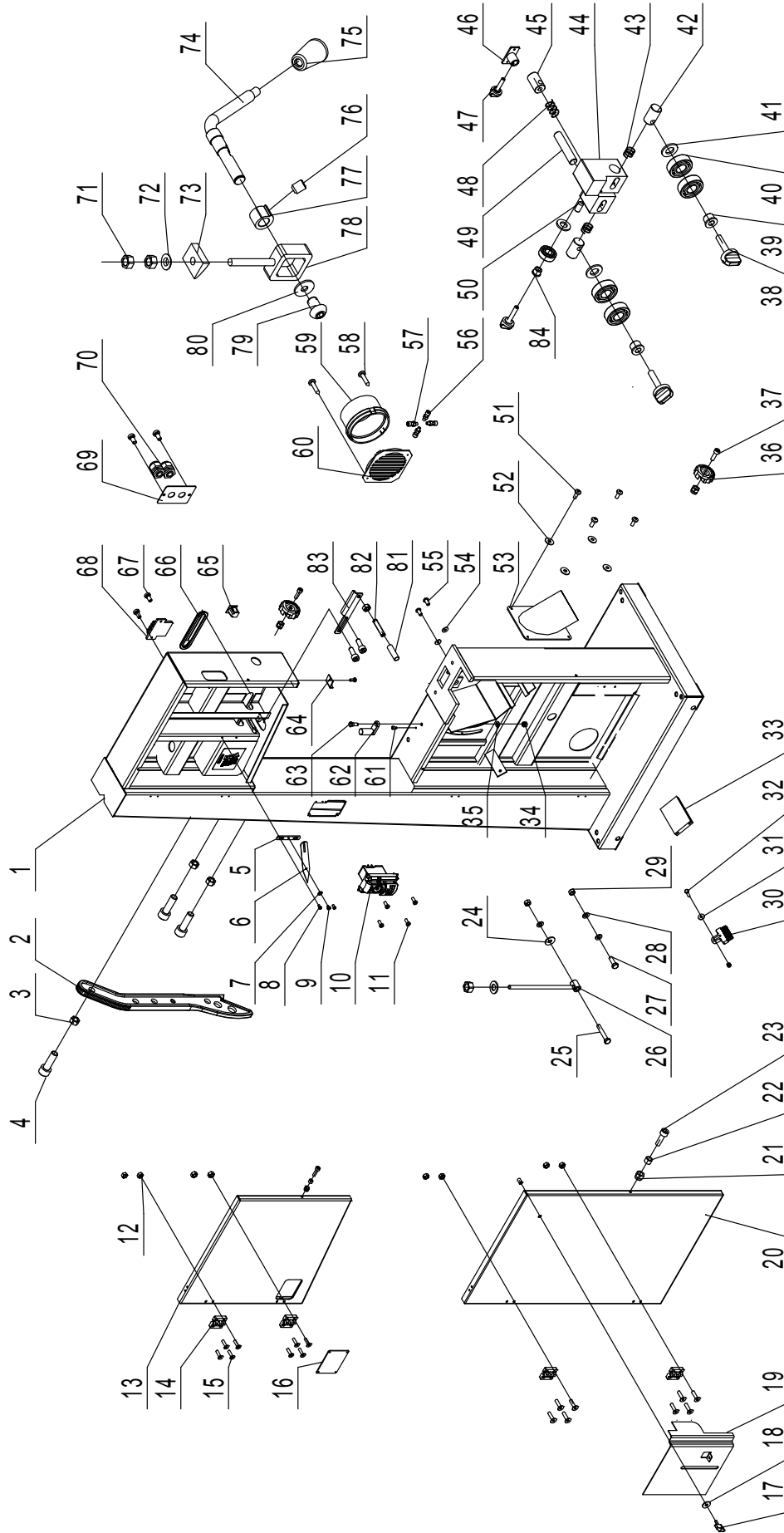

# PARTS LIST

## FRAME ASSEMBLY - SHEET A

KEY NO.	DESCRIPTION	QTY	PART NO.	KEY NO.	DESCRIPTION	QTY	PART NO.
1A	Frame	1	1-JMBS1801011000A-117U	43A	Spring	2	1-JMBS1403014005
2A	Push stick	1	1-JL81100003-146S	44A	Guide block	1	1-JMBS1801052001
3A	Hex nut M6	3	1-M6GB6170B	45A	Lower guide shaft	1	1-JMBS1801016001
4A	Hex bolt	3	1-M6X30GB70D1B	46A	Guide frame	1	1-JMBS1801010001
5A	Batter board	1	1-JL27010005	47A	Locking handle	2	1-JMBS1403014006-001S
6A	Tension indicator arrow	1	1-JL26010004-002A	48A	Spring	1	1-JMBS1401014008
7A	Flat washer	1	1-WSH5GB97D1Z	49A	Guide supporting rod	1	1-JL26041004
8A	Pan head screw M5x10	2	1-M5X10GB818Z	50A	Cap screw M8x10	1	1-M8X10GB80B
9A	Special screw	1	1-JL26010010	51A	Pan head screw M4x10	4	1-M4X10GB818B
10A	Safety On/Off switch	1	1-HY56-6	52A	Big washer	4	1-WSH4GB96B
11A	Pan head screw M4x10	4	1-M4X10GB823B	53A	Dust port	1	1-JXBS2401010013
12A	Hex nut with flange	8	1-M6GB6177B	54A	Big washer	2	1-WSH6GB96B
13A	Upper door cover	1	1-JMBS1801012000A-076U	55A	Screw M6x12	2	1-M6X12GB70D2B
14A	Plastic hinge	4	1-EBBS1801010004	56A	Hex bolt M12x40	4	1-M12X40GB5783B
15A	Hex cap screw M6x20	16	1-M6X20GB70D3B	57A	Hex nut M12	4	1-M12GB6170B
16A	Window	1	1-JL26010001	58A	Tapping screw	2	1-ST3D5X9D5GB845B
17A	Wing nut	1	1-JXBS2401054001-001S	59A	Dust port	1	1-JL20010007-001S
18A	Big washer	1	1-WSH6GB96B	60A	Dust port grating	1	1-JL20010019-001S
19A	Protective cover	1	1-JXBS1804012004-114X	61A	Hex cap screw M5x12	3	1-M5X12GB70D1B
20A	Lower door cover	1	1-JMBS1801013000A-076U	62A	Heel stop block	1	1-FDBS2001014001
21A	Hex locking nut M6	5	1-M6GB889Z	63A	Stud shaft	1	1-JL26010015
22A	Cover	2	1-JL26010007	64A	Scale pointer	1	1-JMBS1403011026-076U
23A	Hex cap screw M6x20	2	1-M6X20GB70D1Z	65A	Electric socket	1	1-DB-F-M
24A	Big washer	1	1-WSH10GB96Z	66A	Dust board	1	1-JL26030019
25A	Hex bolt M10x60	1	1-M10X60GB5783Z	67A	Pan head screw M5x10	4	1-M5X10GB818B
26A	Pull rod	1	1-JMBS1801014001	68A	Tool holder	1	1-JL26090001
27A	Hex bolt M10x30	1	1-M10X30GB5783Z	69A	Threading board	1	1-JL26010011-117U
28A	Flat washer	3	1-WSH10GB97D1Z	70A	Strain relief M20	2	1-JL91046100B
29A	Hex nut M10	3	1-M10GB6170Z	71A	Hex nut M10	2	1-M10GB6170B
30A	Brush	1	1-JL21060003	72A	Washer	1	1-WSH10GB849B
31A	Big washer	3	1-WSH6GB96Z	73A	Heel block	1	1-JMBS1403030004
32A	Hex bolt M6x25	1	1-M6X25GB5783Z	74A	Camshaft handle	1	1-JMBS1801015001
33A	Board	1	1-JXBS1804010002	75A	Knob ball	1	1-1904011
34A	Hex locking nut M8	1	1-M8GB889Z	76A	Hex cap screw M8x8	1	1-M8X8GB80B
35A	Flat washer	1	1-WSH8GB97D1Z	77A	Cam	1	1-JMBS1403016004
36A	Star knob	2	1-JL26010006-001S	78A	Tension	1	1-JMBS1403016003
37A	Hex cap screw M6x25	2	1-M6X25GB70D1Z	79A	Hex cap screw M8x12	1	1-M8X12GB70D2B
38A	Lock handle	2	1-JMBS1801052002-001S	80A	Big washer	1	1-WSH8GB96B
39A	Bearing sleeve	2	1-JMBS1801052003	81A	Plastic tubing	1	1-JXBS2401010018
40A	Bearing	5	1-BRG6202-2RSG276	82A	Set screw M6x30	1	1-M6X30GB77B
41A	Washer	3	1-WSH8GB96B	83A	Upper blade guard	1	1-JMBS1801010006
42A	Guide shaft	2	1-JMBS1403014003	84A	Bearing Sleeve	1	1-JMBS1403014002

# PARTS DIAGRAM

## TABLE ASSEMBLY SHEET B

**NOTE:** Please reference the Manufacturer's Part Number when calling for Replacement Parts.

For Parts under Warranty, the serial number of your machine is required.

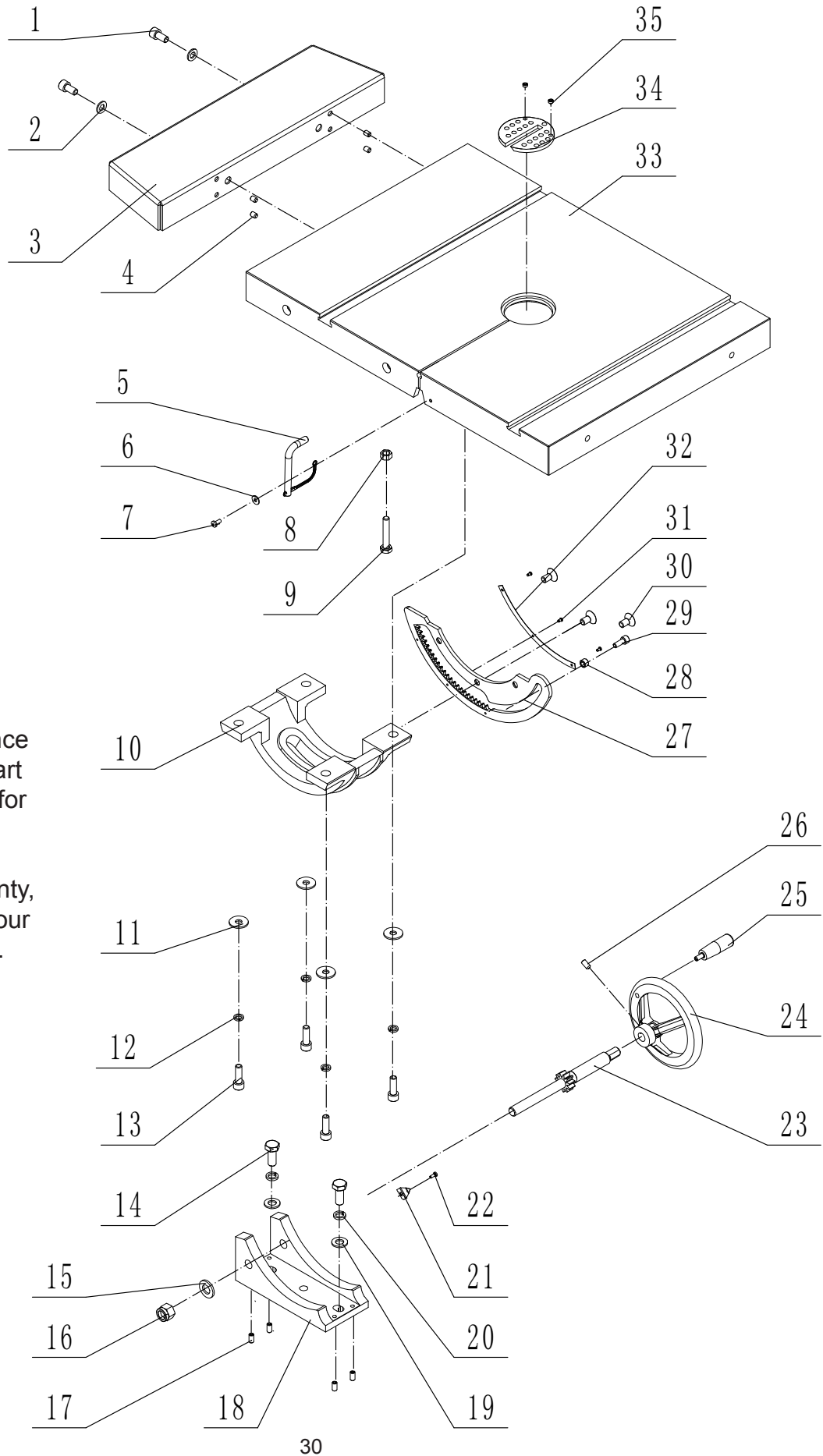

# PARTS LIST

## TABLE ASSEMBLY - SHEET B

KEY NO.	DESCRIPTION	QTY	MFG. PART NO.
1B	Hex socket cap screw M8x16	2	1-M8X16GB70D1Z
2B	Flat washer M8	2	1-WSH8GB97D1Z
3B	Extension table	1	1-JMBS1801030002-076U
4B	Set screw M6x8	4	1-M6X8GB77B
5B	Table support pin assembly	1	1-JMBS1404030002
6B	Big washer	1	1-WSH4GB96Z
7B	Cross recess pan head screw M4x10	1	1-M4X10GB818Z
8B	Nut M8	1	1-M8GB6170B
9B	Hex bolt M8x50	1	1-M8X50GB5781B
10B	Lower table trunnion	1	1-JMBS1403030002
11B	Big washer	4	1-WSH8GB96B
12B	Spring washer	4	1-WSH8GB93B
13B	Hex socket cap screw M8x25	4	1-M8X25GB70D1B
14B	Hex bolt M10x25	2	1-M10X25GB5783B
15B	Flat washer M12	1	1-WSH12GB97D1B
16B	Hex locking nut	1	1-M12GB889B
17B	Set screw M6x12	4	1-M6X12GB77B
18B	Support bracket	1	1-JMBS1403030005
19B	Flat washer	2	1-WSH10GB97D1B
20B	Spring washer	2	1-WSH10GB93B
21B	Table angle pointer	1	1-JXBS2401031008A
22B	Cross recess pan head screw M3x8	1	1-M3X8GB818Z
23B	Gear shaft	1	1-JMBS1403030007A
24B	Handle	1	1-SGSL-D125-d12
25B	Small handle	1	1-JL26020014-001S
26B	Set Screw M6x12	1	1-M6X12GB80B
27B	Rack	1	1-JMBS1403030003
28B	Eccentric bushing	1	1-JMBS1403030008
29B	Screw M6x16	1	1-M6X16GB70D1B
30B	Hex countersunk head screw M8x16	3	1-M8X16GB70D3Z
31B	Rivet	3	1-RVT2D5X5GB827C
32B	Angle scale label	1	1-JMBS1403030006
33B	Table	1	1-JMBS1801030001A-001L
34B	Table insert	1	1-JL26050008A-001S
35B	Set screw M6x4	2	1-M6X4GB77B

# PARTS DIAGRAM

## GUIDE POST ASSEMBLY

### SHEET C

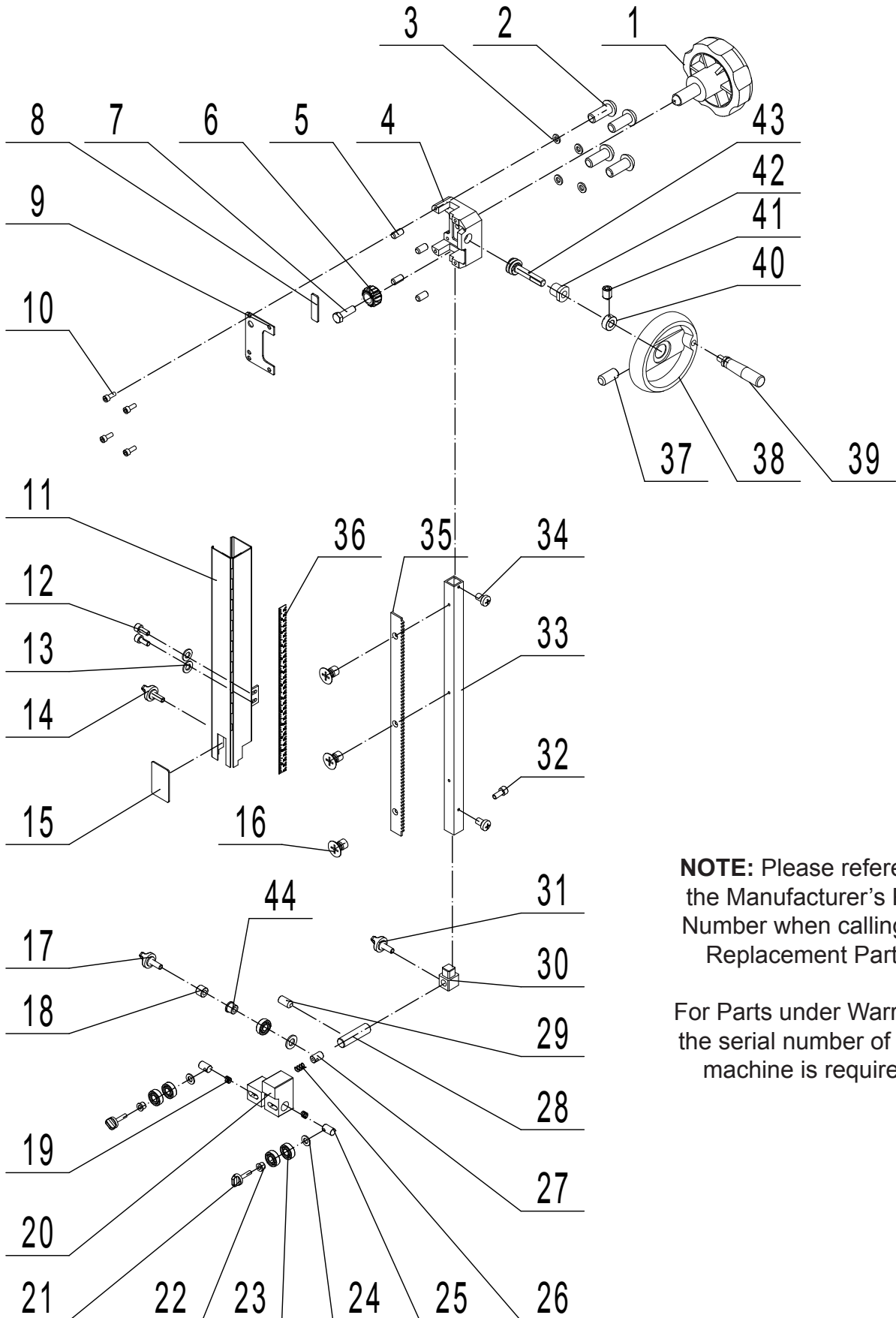

**NOTE:** Please reference the Manufacturer's Part Number when calling for Replacement Parts.

For Parts under Warranty, the serial number of your machine is required.



# PARTS LIST

## GUIDE POST ASSEMBLY - SHEET C

KEY NO.	DESCRIPTION	QTY	MFG. PART NO.
1C	Lock handle	1	1-JL26040015-001S
2C	Hex bolt M8x20	4	1-M8X20GB70D2B
3C	Big washer	4	1-WSH8GB96B
4C	Guide bracket	1	1-JL26040008
5C	Set screw M6x12	4	1-M6X12GB77B
6C	Gear	1	1-1501006
7C	Fixed bolt	1	1-JL26040006
8C	Fixed plate	1	1-JL26040007
9C	Guide bracket cover	1	1-BS5001050001
10C	Hex bolt	4	1-M8X16GB70D1B
11C	Hinged door	1	1-JMBS1801051000B-114X
12C	Hex socket cap screw M5x12	2	1-M5X12GB70D1B
13C	Washer	2	1-WSH5GB97D1B
14C	Lock handle	1	1-JMBS1403050004-001S
15C	Clear window	1	1-JMBS1404050001
16C	Screw M4x10	3	1-M4X10GB819B
17C	Lock handle	1	1-JMBS1801052002-001S
18C	Heel block	1	1-JMBS1403014007
19C	Spring	2	1-JMBS1403014005
20C	Upper guide	1	1-JMBS1801052001
21C	Lock handle	2	1-JMBS1801052002-001S
22C	Bearing sleeve	2	1-JMBS1801052003
23C	Bearing	5	1-BRG6202-2RSGB276
24C	Flat washer	3	1-WSH8GB96B
25C	Guide shaft	2	1-JMBS1403014003
26C	Spring	1	1-JMBS1403014008
27C	Adjust bar	1	1-JMBS1801052004
28C	Guide supporting rod	1	1-JL26041004
29C	Locking screw M6x12	1	1-M8X10GB77B
30C	Upper guide support block	1	1-BS5001052001
31C	Lock handle	1	1-JMBS1403050003-001S
32C	Hex socket cap screw M6x30	1	1-M6X30GB70D1B
33C	Slider bar	1	1-BS5001050003
34C	Pan head screw M5x10	2	1-M5X10GB818B
35C	Rack	1	1-BS6001050001
36C	Scale	1	1-JMBS1403050002
37C	Locking screw M6x12	1	1-M6X12GB77B
38C	Crank handwheel	1	1-SGSL-D100-d12
39C	Small handle	1	1-JL26020014B-001S
40C	Set screw collar	1	1-CLP12GB884B
41C	Set screw M5x8	1	1-M5X8GB78B
42C	Bushing	1	1-JL26040003
43C	Worm cylinder	1	1-JL26040004
44C	Bearing sleeve	1	1-JMBS1403014002

# PARTS DIAGRAM

## BLADE TENSION & TRACKING

### SHEET D

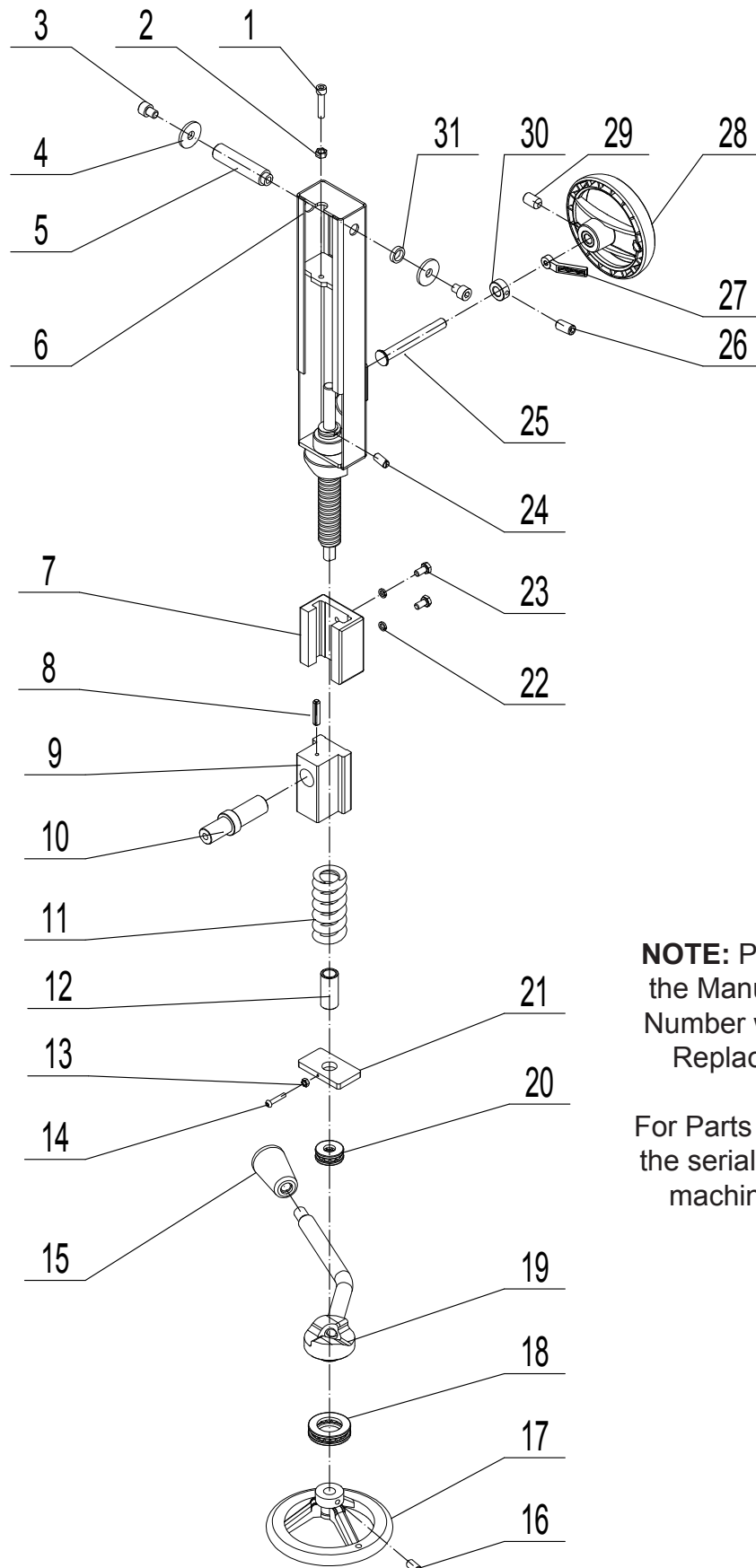

**NOTE:** Please reference the Manufacturer's Part Number when calling for Replacement Parts.

For Parts under Warranty, the serial number of your machine is required.

# PARTS LIST

## BLADE TENSION & TRACKING SHEET D

KEY NO.	DESCRIPTION	QTY	MFG. PART NO.
1D	Hex socket cap screw M6x30	1	1-M6X30GB70D1Z
2D	Hex nut M6	1	1-M6GB6170Z
3D	Hex socket cap screw M8x10	2	1-M8X10GB70Z
4D	Washer	2	1-WSH8GB5287Z
5D	Supporting roller	1	1-JL26030001A
6D	Blade tension bracket assembly	1	1-JL26031000B
7D	Sliding Rail	1	1-JL26030013
8D	Roll pin	1	1-PIN5X35GB879D1B
9D	Upper wheel shaft hinge	1	1-JL26030009A
10D	Upper wheel shaft	1	1-JMBS1801040001
11D	Spring	1	1-JL26030011
12D	Spring bushing	1	1-JL26030002
13D	Hex nut	1	1-M3GB6170B
14D	Screw M3x16	1	1-M3X16GB70D2B
15D	Knob ball	1	1-1904011
16D	Set screw M6x12	1	1-M6X12GB80B
17D	Large tension handwheel	1	1-SGSL-D125-D12
18D	Bearing	1	1-BRG51105GB301
19D	Tension lever with riser block	1	1-JL26030018
20D	Bearing	1	1-BRG51201GB301
21D	Layer board	1	1-JMBS1403040007
22D	Washer	2	1-WSH6GB93Z
23D	Hexagon bolt M6x12	2	1-M6X12GB5783Z
24D	Set screw M5x12	1	1-M5X12GB73B
25D	Stud shaft	1	1-JL26030020
26D	Set screw M5x10	1	1-M5X10GB77B
27D	Locking handle	1	1-JL26030016-001S
28D	Top wheel tilt handwheel	1	1-SGSL-D100-d10
29D	Set screw M6x10	1	1-M6X10GB80B
30D	Retainer ring	1	1-JL26030021
31D	Support sleeve	1	1-JL26030017A

**NOTE:** Please reference the Manufacturer's Part Number when calling for Replacement Parts.  
For Parts under Warranty, the serial number of your machine is required.

# PARTS DIAGRAM & PARTS LIST

## RIP FENCE ASSEMBLY - SHEET E

**NOTE:** Please reference the Manufacturer's Part Number when calling for Replacement Parts.

For Parts under Warranty, the serial number of your machine is required.

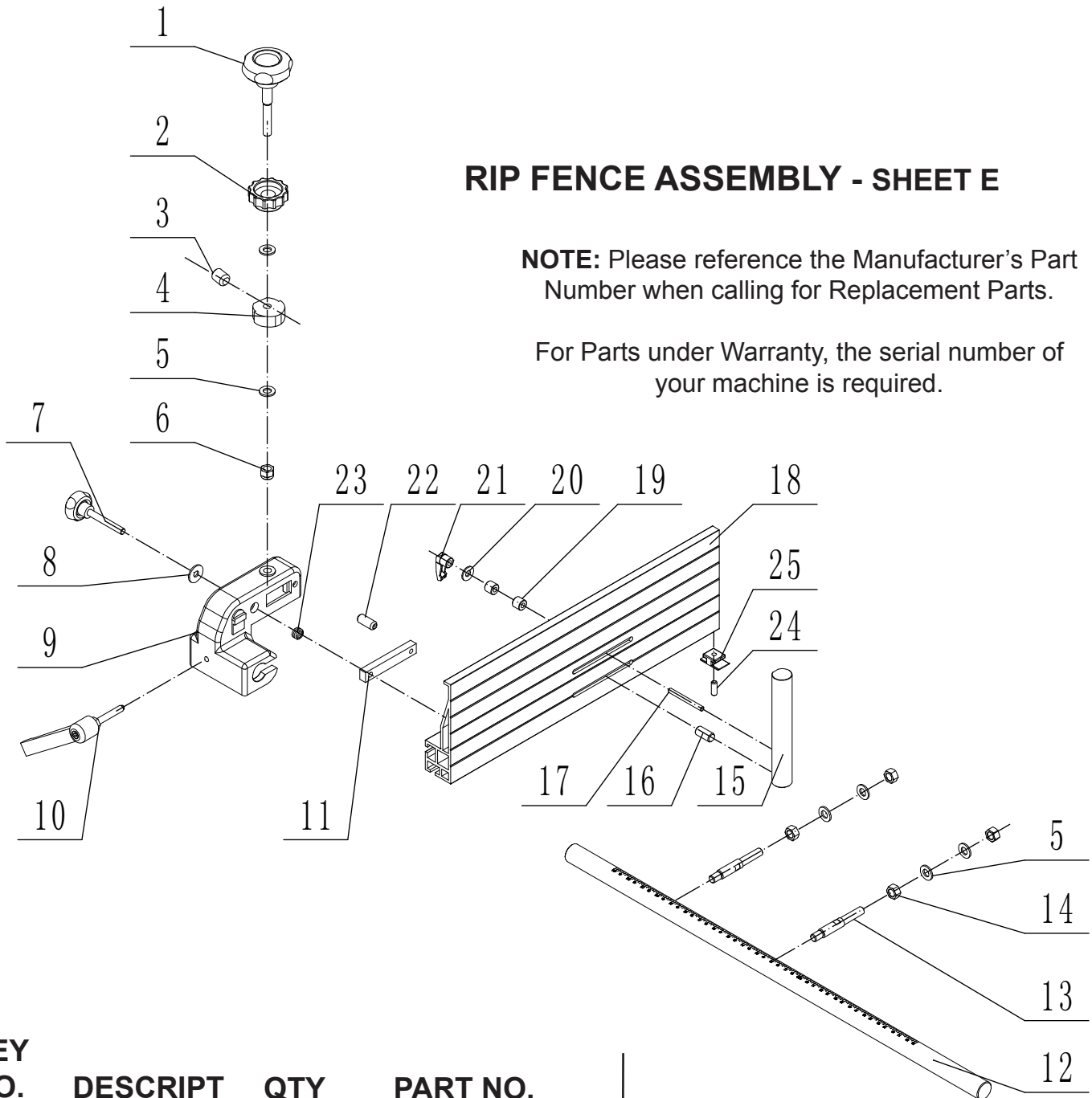

### KEY

NO.	DESCRIPT	QTY	PART NO.
1E	Adjust handle	1	1-JMBS1403060009-001S
2E	Drift locking handle	1	1-JMBS1403060010-001S
3E	Cap screw M8x10	1	1-M8X10GB80B
4E	Cam	1	1-JMBS1403060004
5E	Flat washer	6	1-WSH10GB97D1Z
6E	Hex locking nut M10	1	1-M10GB889D1Z
7E	Fence locking handle	1	1-JMBS1403060003-001S
8E	Big washer	1	1-WSH8GB96Z
9E	Fence carrier	1	1-JMBS1403060001-076U
10E	Carrier locking handle	1	1-JMBS1403060011
11E	Sliding block	1	1-JMBS1403060005
12E	Guide rail	1	1-JMBS1801060004
13E	Connecting rod	2	1-JXBS2001060003
14E	Hex nut	4	1-M10GB6170Z

### KEY

NO.	DESCR	QTY	PART NO.
15E	Re-saw bar	1	1-JMBS1403061001
16E	Screw	1	1-JL26061003
17E	Bolt	1	1-JMBS1403061002
18E	Fence	1	1-JMBS1403060002
19E	Spacer	2	1-JL93010018
20E	Washer	1	1-WSH6GB97D1B
21E	Lock knob	1	1-KTSB-1-A-M6X50
22E	Roll pin	1	1-PIN6X26GB879D1B
23E	Spring	1	1-JMBS1403060007
24E	Set screw	1	1-M6X16GB77B
25E	Nylon plate	1	1-JMBS1401060001

# PARTS DIAGRAM & PARTS LIST

## MOTOR & DRIVE WHEEL ASSEMBLY SHEET F

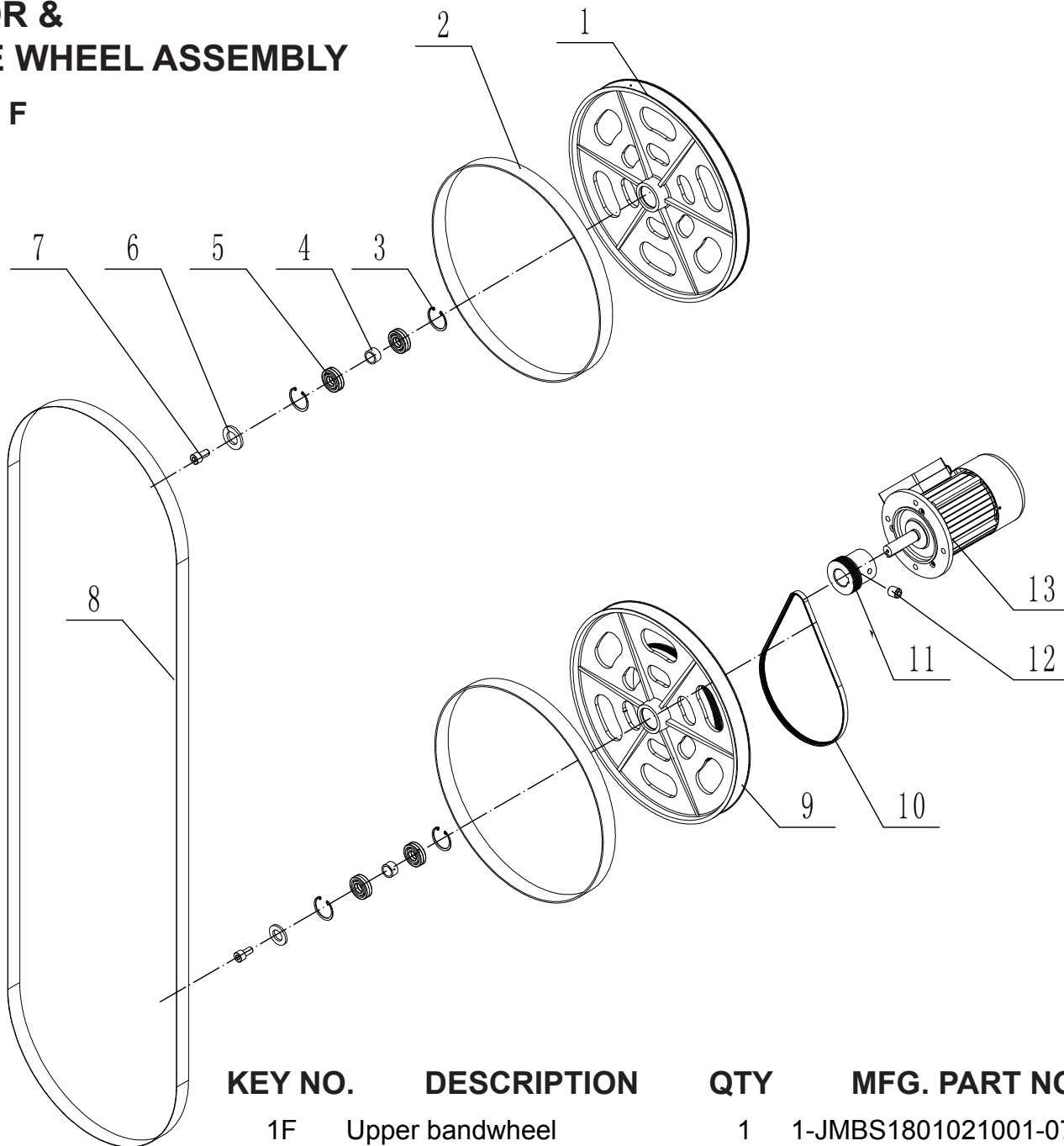

KEY NO.	DESCRIPTION	QTY	MFG. PART NO.
1F	Upper bandwheel	1	1-JMBS1801021001-076Z
2F	Tire	2	1-JXBS1804021002
3F	Circlip ring	4	1-CLP47GB893D1B
4F	Spacer bushing	2	1-JL26030008
5F	Bearing	4	1-BRG6204-2RSGB276
6F	Washer	2	1-JXPS1202070005
7F	Hex screw M8x16	2	1-M8X16GB70D1Z
8F	Bandsaw blade	1	1-JMBS1801020002
9F	Lower bandwheel	1	1-JMBS1801022001-076Z
10F	Multi-vee belt	1	1-5PJ1023GB16588
11F	Motor pulley	1	1-JMBS1801020004A
12F	Socket head cap screw M8X8	2	1-M8X8GB80B
13F	Motor	1	2-YYH903154A

**NOTE:** Please reference the Manufacturer's Part Number when calling for Replacement Parts.

For Parts under Warranty, the serial number of your machine is required.

## ACCESSORIES

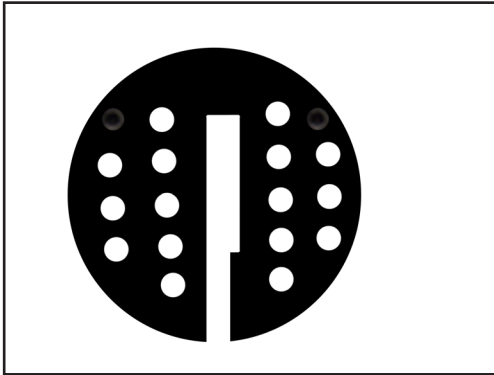

**C10-391 TABLE INSERTS - PK 4**  
Replacement plastic inserts with rear threaded holes for hex screw levellers.

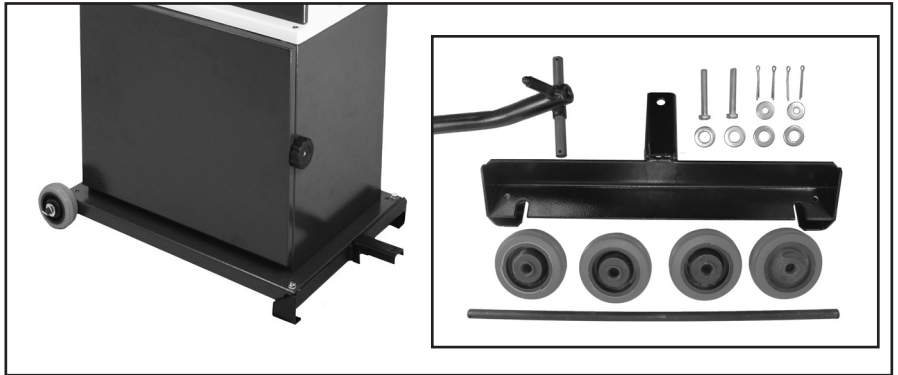

**13-345 MOBILITY KIT** Conversion Kit installs onto the bandsaw base to make it easy to move around the shop. Includes rear wheel assembly, front support, tow bar, hardware and instructions.



**13-912 'T' SLOT MITER GAUGE**  
Fits 3/4" x 3/8" miter slots. Handy scale for up to 60° left and right angle settings, includes adjustable 9" aluminum fence extension and push handle.

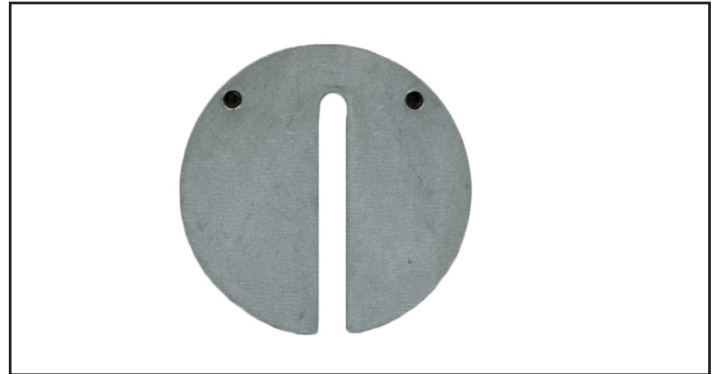

**C10-395 ALUMINUM TABLE INSERT**  
Replacement cast aluminum insert with central slot for positioning the bandsaw blade. Provides solid support and includes rear table levelling screws.



**C10-392 ZERO CLEARANCE INSERTS - PK 4**  
Pack of four plastic inserts with table levelling screws. Inserts have no slot and require user to cut their own on installation. This minimizes the slot width so debris or thin cut wood strips will not catch or fall into the thin slot. Ideal for use when cutting small pieces on the bandsaw for inlay, shims, puzzles, etc.



**BAND SAW BLADES**  
For a complete line of 142" band saw blades, contact your local RIKON Distributor, or visit the RIKON website at [www.rikontools.com](http://www.rikontools.com).



LINK TO RIKON WEBSITE

## WARRANTY

# RIKON

## POWER TOOLS

### 5-Year Limited Warranty

RIKON Power Tools Inc. ("Seller") warrants to only the original retail consumer/purchaser of our products that each product be free from defects in materials and workmanship for a period of five (5) years from the date the product was purchased at retail. This warranty may not be transferred.

This warranty does not apply to defects due directly or indirectly to misuse, abuse, negligence, accidents, repairs, alterations, lack of maintenance or normal wear and tear. Under no circumstances will Seller be liable for incidental or consequential damages resulting from defective products. All other warranties, expressed or implied, whether of merchantability, fitness for purpose, or otherwise are expressly disclaimed by Seller. This warranty does not cover products used for commercial, industrial or educational purposes.

This limited warranty does not apply to accessory items such as blades, drill bits, sanding discs, grinding wheels, belts, ball bearings and other related items.

Seller shall in no event be liable for death, injuries to persons or property, or for incidental, contingent, special, or consequential damages arising from the use of our products.

To take advantage of this warranty, proof of purchase documentation must be provided which has the date of purchase and an explanation of the complaint.

The Seller reserves the right to effect at any time, without prior notice, those alterations to parts, fittings, and accessory equipment which they may deem necessary for any reason whatsoever.

To take advantage of this warranty, please fill out the enclosed warranty card and send it to:

RIKON Warranty  
16 Progress Rd.  
Billerica, MA 01821

The card must be entirely completed in order for it to be valid. If you have any questions please contact us at 877-884-5167 or [warranty@rikontools.com](mailto:warranty@rikontools.com).



For more information:  
16 Progress Road  
Billerica, MA 01821

877-884-5167 / 978-528-5380  
techsupport@rikontools.com

